

# Maximum Rating Tables

Size 824 • GR, NH, EL Series



Single Reduction  
Worm Gear Reducers

Double Reduction  
Worm - Worm Gear Reducers

Double Reduction  
Helical - Worm Gear Reducers

WASHGUARD® Reducers  
and GEAR+MOTOR™

Ratio Multipliers

Accessories and  
Additional Capabilities

Style B

Style H



**Size 824**

Ratio	Input RPM	Output RPM	Input HP	Output HP	Output Torque (lb-in)	Left Hand Catalog No.	Right Hand Catalog No.	Double Extension Catalog No.	Hollow Output Catalog No.*
<b>5</b>	2500	500.0	6.322	5.950	750	_8240001	_8240013	_8240025	_8240501.XX
	1750	350.0	5.323	4.985	898				
	1170	234.0	4.280	3.976	1071				
<b>7.5</b>	100	20.0	0.655	0.489	1540	_8240002	_8240014	_8240026	_8240502.XX
	2500	333.3	4.739	4.401	832				
	1750	233.3	3.992	3.685	995				
<b>10</b>	1170	156.0	3.204	2.929	1183	_8240003	_8240015	_8240027	_8240503.XX
	100	13.3	0.502	0.357	1689				
	2500	250.0	4.199	3.862	974				
<b>15</b>	1750	175.0	3.564	3.253	1172	_8240004	_8240016	_8240028	_8240504.XX
	1170	117.0	2.808	2.531	1364				
	100	10.0	0.442	0.295	1857				
<b>20</b>	2500	166.7	3.268	2.913	1102	_8240005	_8240017	_8240029	_8240505.XX
	1750	116.7	2.765	2.439	1318				
	1170	78.0	2.178	1.888	1526				
<b>25</b>	100	6.7	0.369	0.217	2056	_8240006	_8240018	_8240030	_8240506.XX
	2500	125.0	2.750	2.365	1192				
	1750	87.5	2.326	1.972	1421				
<b>30</b>	1170	58.5	1.835	1.522	1640	_8240007	_8240019	_8240031	_8240507.XX
	100	5.0	0.337	0.174	2193				
	2500	100.0	2.335	1.949	1228				
<b>40</b>	1750	70.0	1.967	1.615	1454	_8240008	_8240020	_8240032	_8240508.XX
	1170	46.8	1.551	1.239	1669				
	100	4.0	0.302	0.140	2205				
<b>50</b>	2500	83.3	1.945	1.579	1194	_8240009	_8240021	_8240033	_8240509.XX
	1750	58.3	1.653	1.317	1423				
	1170	39.0	1.314	1.016	1642				
<b>60</b>	100	3.3	0.270	0.116	2197	_8240010	_8240022	_8240034	_8240510.XX
	2500	62.5	1.574	1.195	1205				
	1750	43.8	1.342	0.994	1433				
<b>80</b>	1170	29.3	1.074	0.766	1650	_8240011	_8240023	_8240035	_8240511.XX
	100	2.5	0.245	0.087	2198				
	2500	50.0	1.335	0.961	1211				
<b>100</b>	1750	35.0	1.137	0.795	1432	_8240012	_8240024	_8240036	_8240512.XX
	1170	23.4	0.911	0.609	1641				
	100	2.0	0.224	0.069	2163				
<b>100</b>	2500	41.7	1.149	0.806	1219	_8240011	_8240023	_8240035	_8240511.XX
	1750	29.2	0.967	0.656	1418				
	1170	19.5	0.770	0.496	1604				
<b>100</b>	100	1.7	0.197	0.054	2054	_8240011	_8240023	_8240035	_8240511.XX
	2500	31.3	0.520	0.348	701				
	1750	21.9	0.455	0.288	830				
<b>100</b>	1170	14.6	0.370	0.219	946	_8240012	_8240024	_8240036	_8240512.XX
	100	1.3	0.056	0.024	1202				
	2500	25.0	0.351	0.219	551				
<b>100</b>	1750	17.5	0.307	0.180	648	_8240012	_8240024	_8240036	_8240512.XX
	1170	11.7	0.251	0.136	735				
	100	1.0	0.039	0.015	926				

**How To Build a Part Number For Size GR824, NH824, EL824**

1. Select partial catalog number from the selection table
2. Replace leading “\_” with series code (GR, NH, EL)
3. For hollow output, replace “XX” suffix with bore code (see next page for codes)

**Example:**

Grove Gear IRONMAN, style B, 5:1 ratio, left hand output  
GR-B824-5-L  
GR8240001

**Style BM**

**Style HM**

**Style BMQ**

**Style HMQ**



NEMA C Input Flange ▲	Style BM			Style HM	Style BMQ			Style HMQ	Ratio
	Left Hand Catalog No.	Right Hand Catalog No.	Double Extension Catalog No.	Hollow Output Catalog No.*	Left Hand Catalog No.	Right Hand Catalog No.	Double Extension Catalog No.	Hollow Output Catalog No.*	
143-5TC 182-4TC	8240073 8240109	8240085 8240121	8240097 8240133	8240525.XX 8240537.XX	8240181 8240217	8240193 8240229	8240205 8240241	8240561.XX 8240573.XX	5
143-5TC 182-4TC	8240074 8240110	8240086 8240122	8240098 8240134	8240526.XX 8240538.XX	8240182 8240218	8240194 8240230	8240206 8240242	8240562.XX 8240574.XX	7.5
143-5TC 182-4TC	8240075 8240111	8240087 8240123	8240099 8240135	8240527.XX 8240539.XX	8240183 8240219	8240195 8240231	8240207 8240243	8240563.XX 8240575.XX	10
56C 143-5TC	8240040 8240076	8240052 8240088	8240064 8240100	8240516.XX 8240528.XX	8240148 8240184	8240160 8240196	8240172 8240208	8240552.XX 8240564.XX	15
56C 143-5TC	8240041 8240077	8240053 8240089	8240065 8240101	8240517.XX 8240529.XX	8240149 8240185	8240161 8240197	8240173 8240209	8240553.XX 8240565.XX	20
56C 143-5TC	8240042 8240078	8240054 8240090	8240066 8240102	8240518.XX 8240530.XX	8240150 8240186	8240162 8240198	8240174 8240210	8240554.XX 8240566.XX	25
56C 143-5TC	8240043 8240079	8240055 8240091	8240067 8240103	8240519.XX 8240531.XX	8240151 8240187	8240163 8240199	8240175 8240211	8240555.XX 8240567.XX	30
56C 143-5TC	8240044 8240080	8240056 8240092	8240068 8240104	8240520.XX 8240532.XX	8240152 8240188	8240164 8240200	8240176 8240212	8240556.XX 8240568.XX	40
56C 143-5TC	8240045 8240081	8240057 8240093	8240069 8240105	8240521.XX 8240533.XX	8240153 8240189	8240165 8240201	8240177 8240213	8240557.XX 8240569.XX	50
56C 143-5TC	8240046 8240082	8240058 8240094	8240070 8240106	8240522.XX 8240534.XX	8240154 8240190	8240166 8240202	8240178 8240214	8240558.XX 8240570.XX	60
56C	8240047	8240059	8240071	8240523.XX	8240155	8240167	8240179	8240559.XX	80
56C	8240048	8240060	8240072	8240524.XX	8240156	8240168	8240180	8240560.XX	100

For input/ output shaft overhung load and thrust load ratings, refer to pages 419-422.

▲ Consult Factory for other motor flanges available.

\* Catalog numbers are for hollow output shaft reducers.

When ordering, substitute the XX suffix with the required output bore code.

**Available bore codes**

Fraction Size	1"	1-1/8"	1-3/16"	1-1/4"	1-7/16"	1-1/2"
Decimal Size	1.000	1.125	1.188	1.250	1.438	1.500
Output Bore Code	16	18	19	20	23	24



# GR Series Dimensions

Styles: HMQ, HM, H

**CAST IRON**  
**GR SERIES**

## Style HMQ

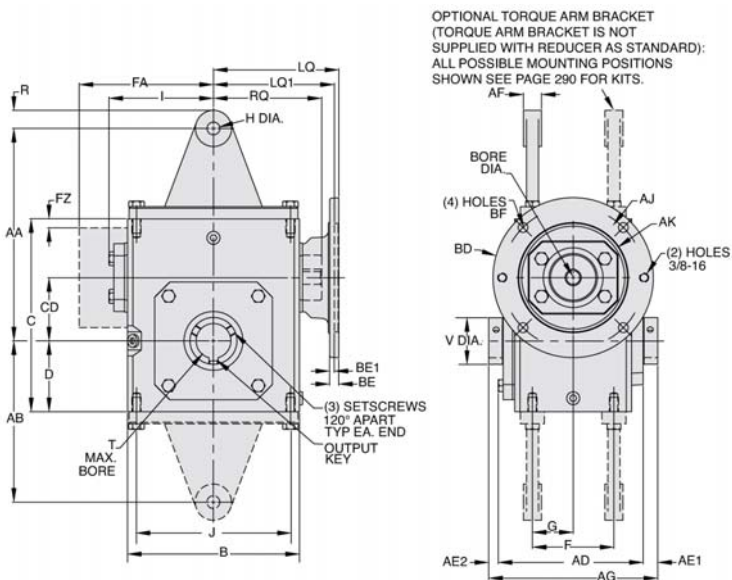

### ASSEMBLIES

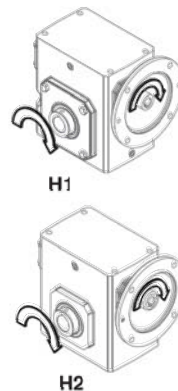

H1 SUPPLIED AS STANDARD UNLESS SPECIFIED.

## Style HM

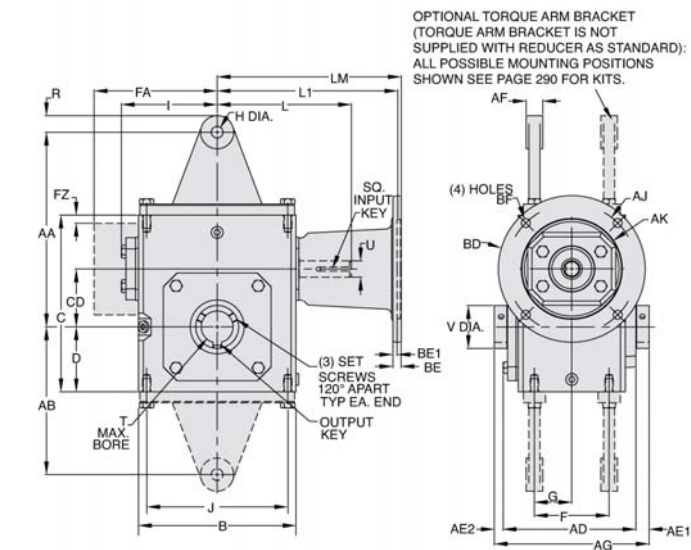

### ASSEMBLIES

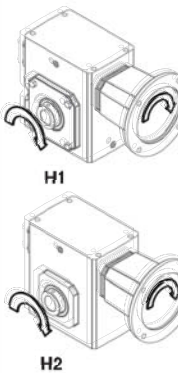

H1 SUPPLIED AS STANDARD UNLESS SPECIFIED.

## Style H

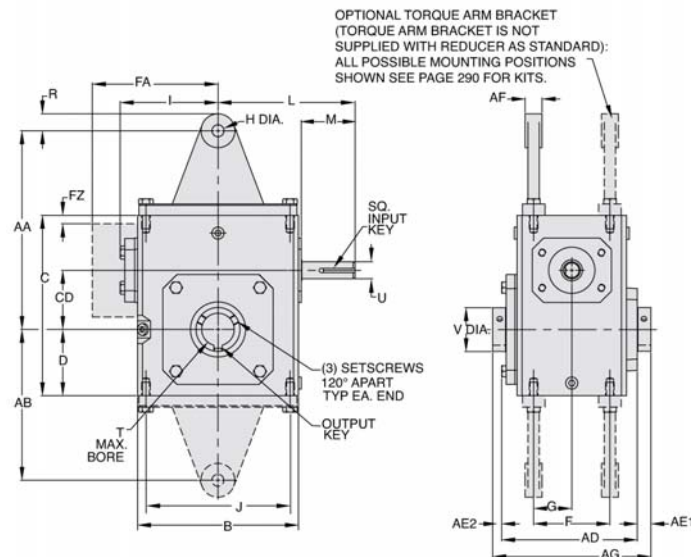

### ASSEMBLIES

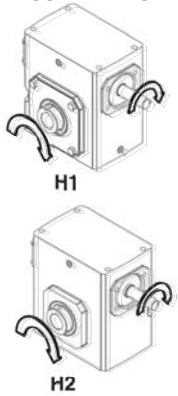

REVERSE ALL ARROWS FOR OPPOSITE INPUT SHAFT ROTATION. CONTACT FACTORY FOR OTHER MOUNTINGS OR ASSEMBLY POSITIONS.

H1 SUPPLIED AS STANDARD UNLESS SPECIFIED.

Single Reduction  
Worm Gear Reducers

Double Reduction  
Worm - Worm Gear Reducers

Double Reduction  
Helical - Worm Gear Reducers

WASHGUARD® Reducers  
and GEAR+MOTOR™

Ratio Multipliers

Accessories and  
Additional Capabilities



**STYLE HMQ, HM, H DIMENSIONS (Inches)**

Series	AD	AE1	AE2	AG	B	C	D	CD	F	FA ▼	FZ ▼	G	I	J	L	M	V	T MAX -0.000 +0.0025	U +0.000 -0.0015	Input Key*	Output Key +
GR813	3.90	0.53	0.32	4.75	3.80	4.66	1.72	1.33	2.00	N/A	N/A	1.00	2.61	3.25	3.82	1.76	1.000	0.625	0.500	1/8 x 1.00	3/16 x 1.50
GR815	4.61	0.51	0.30	5.42	5.19	5.38	1.91	1.54	2.75	N/A	N/A	1.38	3.14	4.19	4.35	1.76	1.000	0.625	0.625	3/16 x 1.38	3/16 x 1.50
GR818	4.73	0.49	0.28	5.50	5.19	5.75	2.06	1.75	2.75	N/A	N/A	1.38	3.24	4.19	4.45	1.76	1.440	1.000	0.625	3/16 x 1.38	1/4 x 3.00
GR821	4.99	0.61	0.40	6.00	5.80	6.38	2.28	2.06	▲	N/A	N/A	1.44	3.61	▲	4.82	1.76	1.940	1.500	0.625	3/16 x 1.38	3/8 x 3.00
GR824	5.18	0.51	0.31	6.00	6.12	6.94	2.50	2.38	2.88	N/A	N/A	1.44	3.77	5.00	5.51	2.38	1.940	1.500	0.750	3/16 x 1.63	3/8 x 3.00
GR826x	6.01	0.60	0.39	7.00	7.38	8.00	2.94	2.63	3.38	N/A	N/A	1.69	4.34	6.38	6.07	2.38	1.940	1.500	0.750	3/16 x 1.63	3/8 x 3.00
GR830	6.53	0.60	0.36	7.50	8.12	8.88	3.25	3.00	4.00	N/A	N/A	2.00	4.84	7.00	6.57	2.38	2.756	2.188	0.875	3/16 x 1.63	1/2 x 3.00
GR832x	7.04	0.54	0.29	7.88	8.75	9.38	3.50	3.25	4.00	N/A	N/A	2.00	5.02	7.50	6.76	2.38	2.756	2.188	0.875	3/16 x 1.63	1/2 x 3.00
GR842	7.53	0.63	0.34	8.50	10.25	11.38	4.44	4.25	5.00	N/A	N/A	2.50	6.10	8.50	9.57	3.47	2.756	2.188	1.250	1/4 x 2.50	1/2 x 3.00
GR852	8.85	0.97	0.68	10.50	13.00	14.00	5.12	5.25	5.81	N/A	N/A	2.91	7.50	11.00	10.88	3.38	4.260	3.438	1.250	1/4 x3.00	7/8 x3.44
GR860	10.52	0.52	0.52	11.50	14.50	16.50	6.50	6.00	6.38	11.13	0.33	3.19	N/A	12.75	11.78	3.41	4.256	3.438	1.500	3/8 x 3.00	7/8 x 3.44
GR870	11.36	1.09	1.09	13.50	14.88	18.91	7.59	7.00	5.50	11.37	0.35	2.75	N/A	12.50	11.50	2.97	4.928	3.938	1.625	3/8 x 2.87**	1 x 1/2**
GR880	12.48	1.03	1.03	14.50	17.00	20.96	8.86	8.00	6.50	12.52	0.57	3.25	N/A	14.25	12.50	2.84	5.553	4.438	1.875	1/2 x 2.81**	1 x 1/2**
GR8100	15.78	1.39	1.39	18.50	20.88	25.47	10.36	10.00	6.88	14.69	0.51	3.44	N/A	14.75	15.50	3.76	4.256	5.438	2.250	1/2 x 3.69**	1-1/4 x 5/8**

▲ See feature comparison chart.

**FEATURE COMPARISON (821)**

Size	Output Shaft Diameter Needed?	Mounting Footprint Needed?	Output Key Needed?	All Other Features	Grove Gear Flexaline Interchange	LEESON IRONMAN Interchange	Replace With Series Code Below:
GR821	Identical	(F)3.00" x (J)4.75" (F)2.88" x (J)5.00"	Identical	Identical	✓	✓	GRG GRL

NOTE: If reducer is used without the accessory mounted, select based mounting dimensions on pages 52-53 (B, BM, BMQ).

**Motor Mounting Dimensions  
NEMA DIMENSIONS (Inches)**

Size	LM	56C/140TC	L1	LQ	180TC	LQ1	250TC	RQ	250TC
GR813	5.63	6.07	N/A	N/A	3.46	N/A	N/A	3.09	N/A
GR815	6.16	6.60	N/A	N/A	3.99	N/A	N/A	3.62	N/A
GR818	6.26	6.70	N/A	N/A	4.09	N/A	N/A	3.59	N/A
GR821*	6.63	7.07	N/A	N/A	4.46	N/A	N/A	4.06	N/A
GR824	N/A	7.76	8.76	N/A	4.63	5.06	N/A	4.09	4.56
GR826*	N/A	8.32	9.32	N/A	5.19	5.62	N/A	4.82	5.13
GR830	N/A	8.82	9.82	N/A	5.95	6.15	6.56	5.32	5.63
GR832*	N/A	9.01	10.01	N/A	6.14	6.34	6.75	5.51	5.81
GR842	N/A	11.81	12.90	13.46	6.45	7.21	7.77	6.04	6.68
GR852	N/A	13.21	14.30	14.86	7.85	8.61	9.17	7.35	7.98
GR860	N/A	N/A	15.88	16.50	10.45	9.33	9.94	10.01	8.69
GR870	N/A	N/A	15.50	16.50	N/A	N/A	N/A	N/A	N/A
GR880	N/A	N/A	16.58	16.58	N/A	N/A	N/A	N/A	N/A

**NEMA DIMENSIONS (Inches)**

Frame	AJb	AK	BD	BE	BE1	Bore Dia.	Keyway♦	BfB
	3.75	3.00	4.36	0.38	N/A	.500	1/8 X 1/16	0.28
56C	5.88	4.50	6.50	0.38	N/A	.625	3/16 X 3/32	0.41
140TC	5.88	4.50	6.50	0.38	N/A	.875	3/16 X 3/32	0.41
180TC	7.25	8.50	9.00	N/A	0.50	1.125	1/4 X 1/8	0.53
210TC	7.25	8.50	9.00	N/A	0.50	1.375	5/16 X 5/32	0.53
250TC	7.25	8.50	9.00	N/A	0.50	1.625	3/8 X 3/16	0.53

**IEC B5 & B3/B5 METRIC DIMENSIONS (Inches)♦**

Size	D63D	D71D	D80D	D90D	D100LD/D112MD	D132D	D63D	D71D	D80D	D90D	D100LD/D112MD	D132D
GR813	2.62	2.65	2.89	N/A	N/A	N/A	2.45	2.47	2.71	N/A	N/A	N/A
GR815	3.15	3.18	3.42	N/A	N/A	N/A	2.98	3.00	3.24	N/A	N/A	N/A
GR818	3.25	3.28	3.52	N/A	N/A	N/A	2.95	2.97	3.21	N/A	N/A	N/A
GR821*	3.62	3.65	3.89	N/A	N/A	N/A	3.43	3.44	3.68	N/A	N/A	N/A
GR824	N/A	3.72	4.34	N/A	N/A	N/A	3.46	3.71	N/A	N/A	N/A	N/A
GR826*	N/A	4.28	4.90	4.90	5.30	N/A	N/A	4.09	4.72	4.72	5.07	N/A
GR830	N/A	4.78	5.41	5.41	5.88	N/A	N/A	4.59	5.22	5.22	5.57	N/A
GR832*	N/A	4.97	5.59	5.59	6.07	N/A	N/A	4.78	5.41	5.41	5.76	N/A
GR842	N/A	N/A	N/A	6.38	6.39	7.17	N/A	N/A	N/A	6.16	6.14	6.93
GR852	N/A	N/A	N/A	7.78	7.78	8.57	N/A	N/A	N/A	7.46	7.45	8.24

**IEC B5 & B3/B5 METRIC DIMENSIONS (MM)**

Frame	AJ	AK	BD	BE	Bore Dia.	Keyway♦	BF TAP	OD
D63D	115	95	117	10	11	4 X 2	M8 X 1.25	131
D71D	130	110	132	11	14	5 X 2.5	M8 X 1.25	146
D80D	165	130	165	15	19	6 X 3	M10 X 1.50	184
D90D	165	130	165	15	24	8 X 3.5	M10 X 1.50	184
D100LD/D112MD	215	180	216	18	28	8 X 3.5	M12 X 1.75	237
D132D	265	230	267	18	38	10 X 4	M12 X 1.75	290

♦ Max bore dimensions shown. For additional bores available, refer to page 20.

\* Applies to double output shaft

\*\* Key not provided with gear reducer. Keyway dimension shown.

♦ Keyway width by depth

⊙ Mounting holes rotated 45 degrees from positions shown on Size GR860, Style HM with frame sizes 180TC-250TC.

■ 48CZ not available

● 180TC not available

♦ Metric IEC B5 input flange options are available only on quill input styles.

✖ Dimensions same for GRG and GRL Series

\* Style H and HM only.

▼ Sizes 860-8100 are supplied with a fan. Dimensions refer to fan guard location.

Note: Torque arm bracket available separately. Refer to page 274 for kits. If a special bracket is required, refer to Style BMQ dimensions for mounting pad dimensions on top/bottom of reducer.



For safety, purchaser or user should provide protective guards over shaft extensions and any couplings, sheaves and belts, sprockets and chains, etc., mounted thereon.

Single Reduction  
Worm Gear Reducers

Double Reduction  
Worm - Worm Gear Reducers

Double Reduction  
Helical - Worm Gear Reducers

WASHGARD® Reducers  
and GEAR-HMOTOR™

Ratio Multipliers

Accessories and  
Additional Capabilities