

Maximum Rating Tables

Size 821 • GR, NH, EL Series



Style B

Style H



Size 821

Ratio	Input RPM	Output RPM	Input HP	Output HP	Output Torque (lb-in)	Left Hand Catalog No.	Right Hand Catalog No.	Double Extension Catalog No.	Hollow Output Catalog No.*
5	2500	500	4.305	4.043	510	_8210001	_8210013	_8210025	_8210501.XX
	1750	350	3.653	3.410	614				
	1170	234	2.873	2.657	716				
7.5	100	20	0.433	0.310	977	_8210002	_8210014	_8210026	_8210502.XX
	2500	333	3.300	3.051	577				
	1750	233	2.793	2.562	692				
10	1170	156	2.194	1.989	804	_8210003	_8210015	_8210027	_8210503.XX
	100	13	0.341	0.230	1089				
	2500	250	2.973	2.722	686				
15	1750	175	2.464	2.235	805	_8210004	_8210016	_8210028	_8210504.XX
	1170	117	1.905	1.702	917				
	100	10	0.300	0.189	1192				
20	2500	166	2.284	2.035	769	_8210005	_8210017	_8210029	_8210505.XX
	1750	116	1.887	1.661	897				
	1170	78	1.459	1.259	1017				
25	100	6.7	0.245	0.138	1309	_8210006	_8210018	_8210030	_8210506.XX
	2500	125	1.914	1.642	828				
	1750	87	1.584	1.338	964				
30	1170	58	1.229	1.012	1090	_8210007	_8210019	_8210031	_8210507.XX
	100	5.0	0.226	0.111	1397				
	2500	100	1.623	1.359	857				
40	1750	70	1.333	1.094	985	_8210008	_8210020	_8210032	_8210508.XX
	1170	46	1.030	0.820	1104				
	100	4.0	0.200	0.088	1386				
50	2500	83	1.359	1.102	833	_8210009	_8210021	_8210033	_8210509.XX
	1750	58	1.129	0.896	968				
	1170	39	0.882	0.677	1095				
60	100	3.3	0.181	0.074	1399	_8210010	_8210022	_8210034	_8210510.XX
	2500	62	1.096	0.829	836				
	1750	43	0.916	0.674	971				
80	1170	29	0.722	0.509	1097	_8210011	_8210023	_8210035	_8210511.XX
	100	2.5	0.167	0.056	1401				
	2500	50	0.925	0.670	845				
100	1750	35	0.769	0.539	970	_8210012	_8210024	_8210036	_8210512.XX
	1170	23	0.606	0.403	1086				
	100	2.0	0.149	0.043	1359				

How To Build a Part Number For Size GRG821, GRL821, NH821, EL821

1. Select partial catalog number from the selection table
2. Replace leading “_” with series code (GRG, GRL, NH, EL) (see next page for codes)
3. For hollow output, replace “XX” suffix with bore code

Example:

Direct replacement to LEESON IRONMAN, style B, 5:1 ratio, left hand output
 GRL-B821-5-L
 GRL8210001

GRG = **GROVE GEAR**

- Direct replacement to Grove Gear Flexaline
- Mounting footprint 3.00" x 4.75"
- See pages 52-73 for dimensions

GRL = **IRONMAN** Interchange

- Direct replacement to LEESON IRONMAN & major brands.
- Mounting footprint 2.88" x 5.00"
- See pages 52-73 for dimensions



Single Reduction
Worm Gear Reducers

Double Reduction
Worm - Worm Gear Reducers

Double Reduction
Helical - Worm Gear Reducers

WASHGUARD® Reducers
and GEAR+MOTOR™

Ratio Multipliers

Accessories and
Additional Capabilities



Maximum Rating Tables

Size 821 • GR, NH, EL Series

	Style BM			Style HM	Style BMQ			Style HMQ	
NEMA C Input Flange ▲	Left Hand Catalog No.	Right Hand Catalog No.	Double Extension Catalog No.	Hollow Output Catalog No.*	Left Hand Catalog No.	Right Hand Catalog No.	Double Extension Catalog No.	Hollow Output Catalog No.*	Ratio
56C 143-5TC	<u>8210037</u> <u>8210073</u>	<u>8210049</u> <u>8210085</u>	<u>8210061</u> <u>8210097</u>	<u>8210513.XX</u> <u>8210525.XX</u>	<u>8210109</u> <u>8210145</u>	<u>8210121</u> <u>8210157</u>	<u>8210133</u> <u>8210169</u>	<u>8210537.XX</u> <u>8210549.XX</u>	5
56C 143-5TC	<u>8210038</u> <u>8210074</u>	<u>8210050</u> <u>8210086</u>	<u>8210062</u> <u>8210098</u>	<u>8210514.XX</u> <u>8210526.XX</u>	<u>8210110</u> <u>8210146</u>	<u>8210122</u> <u>8210158</u>	<u>8210134</u> <u>8210170</u>	<u>8210538.XX</u> <u>8210550.XX</u>	7.5
56C 143-5TC	<u>8210039</u> <u>8210075</u>	<u>8210051</u> <u>8210087</u>	<u>8210063</u> <u>8210099</u>	<u>8210515.XX</u> <u>8210527.XX</u>	<u>8210111</u> <u>8210147</u>	<u>8210123</u> <u>8210159</u>	<u>8210135</u> <u>8210171</u>	<u>8210539.XX</u> <u>8210551.XX</u>	10
56C 143-5TC	<u>8210040</u> <u>8210076</u>	<u>8210052</u> <u>8210088</u>	<u>8210064</u> <u>8210100</u>	<u>8210516.XX</u> <u>8210528.XX</u>	<u>8210112</u> <u>8210148</u>	<u>8210124</u> <u>8210160</u>	<u>8210136</u> <u>8210172</u>	<u>8210540.XX</u> <u>8210552.XX</u>	15
56C 143-5TC	<u>8210041</u> <u>8210077</u>	<u>8210053</u> <u>8210089</u>	<u>8210065</u> <u>8210101</u>	<u>8210517.XX</u> <u>8210529.XX</u>	<u>8210113</u> <u>8210149</u>	<u>8210125</u> <u>8210161</u>	<u>8210137</u> <u>8210173</u>	<u>8210541.XX</u> <u>8210553.XX</u>	20
56C 143-5TC	<u>8210042</u> <u>8210078</u>	<u>8210054</u> <u>8210090</u>	<u>8210066</u> <u>8210102</u>	<u>8210518.XX</u> <u>8210530.XX</u>	<u>8210114</u> <u>8210150</u>	<u>8210126</u> <u>8210162</u>	<u>8210138</u> <u>8210174</u>	<u>8210542.XX</u> <u>8210554.XX</u>	25
56C 143-5TC	<u>8210043</u> <u>8210079</u>	<u>8210055</u> <u>8210091</u>	<u>8210067</u> <u>8210103</u>	<u>8210519.XX</u> <u>8210531.XX</u>	<u>8210115</u> <u>8210151</u>	<u>8210127</u> <u>8210163</u>	<u>8210139</u> <u>8210175</u>	<u>8210543.XX</u> <u>8210555.XX</u>	30
56C 143-5TC	<u>8210044</u> <u>8210080</u>	<u>8210056</u> <u>8210092</u>	<u>8210068</u> <u>8210104</u>	<u>8210520.XX</u> <u>8210532.XX</u>	<u>8210116</u> <u>8210152</u>	<u>8210128</u> <u>8210164</u>	<u>8210140</u> <u>8210176</u>	<u>8210544.XX</u> <u>8210556.XX</u>	40
56C 143-5TC	<u>8210045</u> <u>8210081</u>	<u>8210057</u> <u>8210093</u>	<u>8210069</u> <u>8210105</u>	<u>8210521.XX</u> <u>8210533.XX</u>	<u>8210117</u> <u>8210153</u>	<u>8210129</u> <u>8210165</u>	<u>8210141</u> <u>8210177</u>	<u>8210545.XX</u> <u>8210557.XX</u>	50
48CZ 56C 143-5TC	<u>8210190</u> <u>8210046</u> <u>8210082</u>	<u>8210202</u> <u>8210058</u> <u>8210094</u>	<u>8210214</u> <u>8210070</u> <u>8210106</u>	<u>8210570.XX</u> <u>8210522.XX</u> <u>8210534.XX</u>	<u>8210226</u> <u>8210118</u> <u>8210154</u>	<u>8210238</u> <u>8210130</u> <u>8210166</u>	<u>8210250</u> <u>8210142</u> <u>8210178</u>	<u>8210582.XX</u> <u>8210546.XX</u> <u>8210558.XX</u>	60
48CZ 56C	<u>8210191</u> <u>8210047</u>	<u>8210203</u> <u>8210059</u>	<u>8210215</u> <u>8210071</u>	<u>8210571.XX</u> <u>8210523.XX</u>	<u>8210227</u> <u>8210119</u>	<u>8210239</u> <u>8210131</u>	<u>8210251</u> <u>8210143</u>	<u>8210583.XX</u> <u>8210547.XX</u>	80
48CZ 56C	<u>8210192</u> <u>8210048</u>	<u>8210204</u> <u>8210060</u>	<u>8210216</u> <u>8210072</u>	<u>8210572.XX</u> <u>8210524.XX</u>	<u>8210228</u> <u>8210120</u>	<u>8210240</u> <u>8210132</u>	<u>8210252</u> <u>8210144</u>	<u>8210584.XX</u> <u>8210548.XX</u>	100

For input/ output shaft overhung load and thrust load ratings, refer to pages 419-422.

▲ Consult Factory for other motor flanges available.

* Catalog numbers are for hollow output shaft reducers.

When ordering, substitute the XX suffix with the required output bore code.

Available bore codes

Fraction Size	1"	1-1/8"	1-3/16"	1-1/4"	1-7/16"	1-1/2"
Decimal Size	1.000	1.125	1.188	1.250	1.438	1.500
Output Bore Code	16	18	19	20	23	24

Single Reduction
Worm Gear Reducers

Double Reduction
Worm - Worm Gear Reducers

Double Reduction
Helical - Worm Gear Reducers

WASHGUARD® Reducers
and GEAR+MOTOR™

Ratio Multipliers

Accessories and
Additional Capabilities

ELECTRA-GEAR

EL Series Dimensions

Styles: UMQ, UM, U

Style UMQ

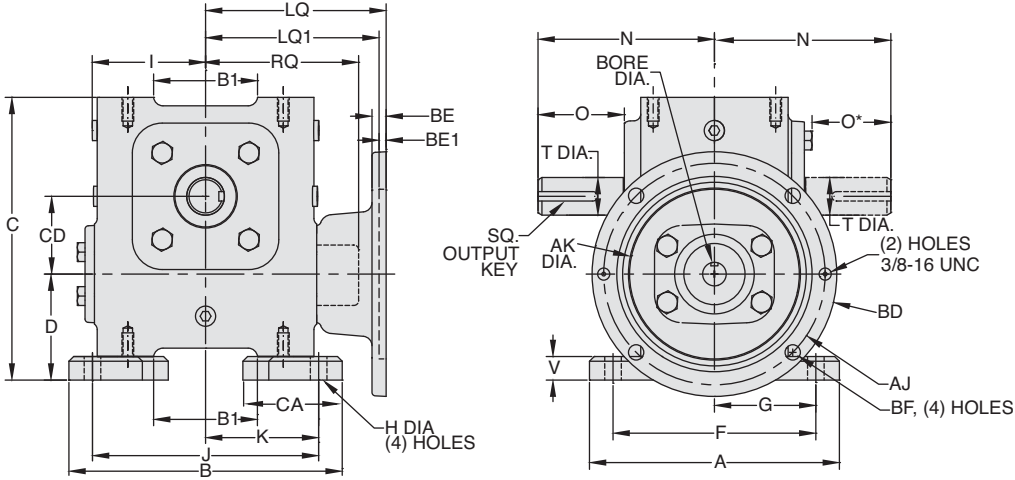

Style UM

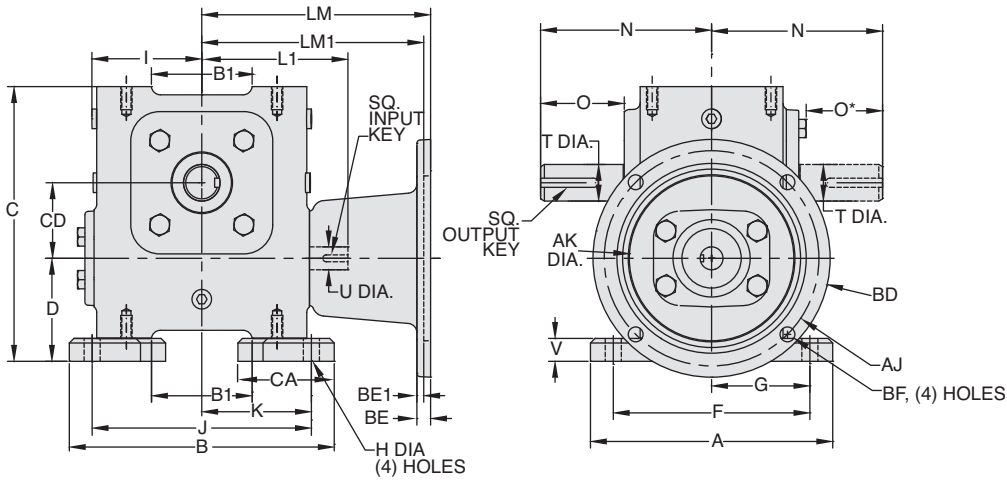

Style U

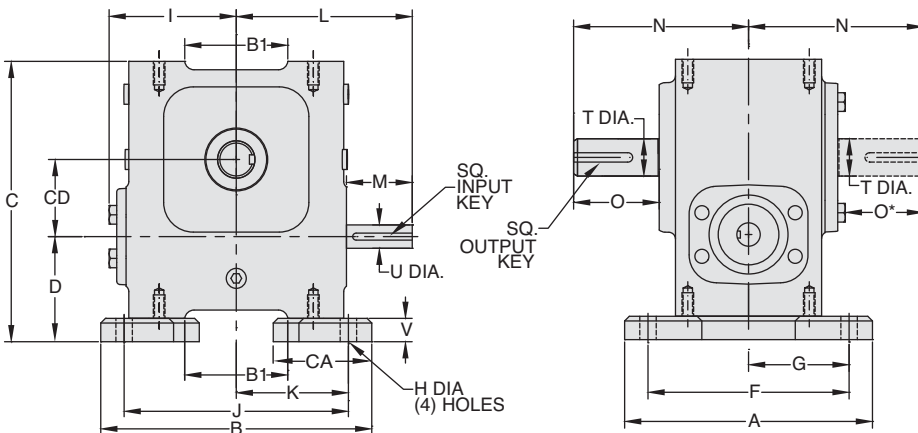

ASSEMBLIES

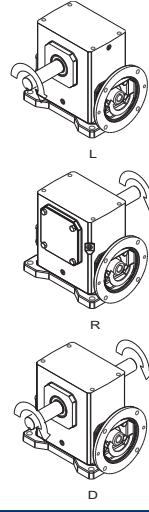

ASSEMBLIES

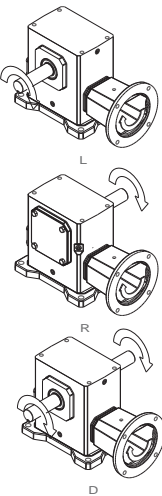

ASSEMBLIES

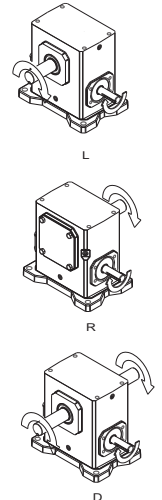

REVERSE ALL ARROWS FOR OPPOSITE INPUT SHAFT ROTATION. CONTACT FACTORY FOR OTHER MOUNTINGS OR ASSEMBLY POSITIONS.

Single Reduction
Worm Gear Reducers

Double Reduction
Worm - Worm Gear Reducers

Double Reduction
Helical - Worm Gear Reducers

WASHGUARD® Reducers
and GEAR+MOTOR™

Ratio Multipliers

Accessories and
Additional Capabilities

STYLE UMQ, UM, U DIMENSIONS (Inches)

Size	A	B	B1	C	CA	CD	D	F	G	H	I	J	K	L	M	N	O	O*	V	T +0.000 -0.0015	U +0.000 -0.0015	Input Key (Style U Only)	Input Key (Style UM only)	Output Key
EL813	4.06	5.13	--	5.19	1.56	1.33	2.13	3.31	1.66	0.34	2.40	4.38	2.19	3.82	1.87	4.00	2.16	1.96	0.53	0.625	0.500	1/8 x 1.00	1/8 x 1.00	3/16 x 1.38
EL818	5.19	6.06	2.48	6.42	2.15	1.75	2.37	4.38	2.19	0.38	3.03	5.25	2.63	4.35	1.78	4.39	2.05	1.85	0.56	0.750	0.625	3/16 x 1.38	3/16 x .500	3/16 x 1.38
EL821	6.63	7.25	2.76	7.51	2.66	2.06	2.82	5.38	2.69	0.44	3.40	6.00	3.00	4.71	1.76	4.68	2.29	2.09	0.63	1.000	0.625	3/16 x 1.38	3/16 x .500	1/4 x 1.44
EL824	6.38	7.69	--	7.63	2.59	2.38	2.81	4.88	2.44	0.47	3.61	6.19	3.09	5.51	2.45	5.14	2.66	2.46	0.75	1.125	0.750	3/16 x 1.63	3/16 x .500	1/4 x 1.62
EL826	6.63	8.13	4.21	8.69	2.81	2.63	2.81	5.38	2.69	0.50	4.17	6.88	3.44	6.07	2.45	5.63	2.73	2.53	0.69	1.250	0.750	3/16 x 1.63	3/16 x .500	1/4 x 1.62
EL830	9.00	9.88	4.50	9.69	3.69	3.00	3.19	7.50	3.75	0.56	4.81	8.38	4.19	6.56	2.31	6.62	3.60	3.37	0.75	1.500	0.875	3/16 x 1.63	3/16 x .500	3/8 x 2.25
EL832	9.13	10.88	4.53	11.25	3.69	3.25	4.00	7.63	3.82	0.56	5.00	9.38	4.69	6.75	2.31	6.62	3.60	3.37	0.75	1.625	0.875	3/16 x 1.63	3/16 x .500	3/8 x 2.25
EL842	10.00	10.50	5.71	12.94	3.38	4.25	4.19	8.00	4.00	0.81	6.15	8.50	4.25	9.57	3.47	8.12	4.50	4.22	1.25	1.750	1.250	1/4 x 2.50	1/4 x 2.50	3/8 x 3.00
EL852	10.75	12.13	7.82	13.75	2.50	5.25	4.25	8.75	4.38	0.81	7.55	9.75	4.88	10.88	3.38	9.06	4.78	4.50	1.50	2.000	1.250	1/4 x 3.00	1/4 x 3.00	1/2 x 2.50
EL860	11.75	13.50	--	16.00	4.35	6.00	5.00	9.50	4.75	0.94	7.88	10.50	5.25	10.99	3.00	10.75	5.25	5.25	1.75	2.250	1.500	3/8 x 3.00	3/8 x 2.75	1/2 x 4.00

Motor Mounting Dimensions

NEMA DIMENSIONS (Inches)

Size	LM 56C/140TC	LM1 180TC / 210TC	L1 56C/140TC 180TC / 210TC	LQ 56C/140TC	LQ1 180TC / 210TC	RQ 56C/140TC 180TC / 210TC
EL813	6.07	--	3.82	--	3.79	--
EL818	5.89	--	3.64	--	4.42	--
EL821	6.26	--	4.00	--	4.79	--
EL824	6.48	7.30	4.29	4.29	4.77	4.09
EL826	7.04	7.86	4.88	4.88	5.33	4.82
EL830	7.67	8.31	5.38	5.38	5.97	5.32
EL832	7.86	8.50	5.56	5.56	6.16	5.51
EL842	11.25	12.53	9.57	9.57	6.45	6.04
EL852	12.65	13.93	10.88	10.88	7.85	7.35
EL860	--	11.94	10.99	--	--	--

NEMA DIMENSIONS (Inches)

Frame	AJ	AK	BD	BE	BE1	Bore Dia.	Keyway♦	BF
56C	5.88	4.50	6.50	0.38	N/A	.625	3/16 X 3/32	0.41
140TC	5.88	4.50	6.50	0.38	N/A	.875	3/16 X 3/32	0.41
180TC	7.25	8.50	9.00	N/A	0.50	1.125	1/4 X 1/8	0.53
210TC	7.25	8.50	9.00	N/A	0.50	1.375	5/16 X 5/32	0.53

- * Applies to double output shaft
- ♦ Keyway width by depth
- * Solid input shaft and C-faced coupling input reducers have different input shaft length and key.



WARNING For safety, purchaser or user should provide protective guards over shaft extensions and any couplings, sheaves and belts, sprockets and chains, etc., mounted thereon.

INTEGRAL GEARMOTOR INPUTS AVAILABLE

— Contact Factory for price and availability.

EL SERIES MOUNTING DIMENSIONS

- EL Series mounting dimensions are the same as the original ELECTRA-GEAR product with an option to match the industry standard dimensions of GR Series.
- See page 52 for GR Series dimensions.

ELECTRA-GEAR INTERCHANGE GUIDE

Original Style	New Style
NOT A	UMQ
STANDARD CATALOGED	UM
OPTION	U

Convert Style U to motorized coupling input using kits shown on page 278.