

PRODUCT INFORMATION PACKET



Model No: H734
Catalog No: H734

General Purpose Pump Motor, 3.0 HP, 3 Ph, 60 Hz, 200-230/460 V, 3600 RPM, N56J Frame, DP



Regal and Century are trademarks of Regal Rexnord Corporation or one of its affiliated companies.
©2022 Regal Rexnord Corporation, All Rights Reserved. MC017097E





Nameplate Specifications

Output HP	3.0 Hp	Output KW	2.2 kW
Frequency	60 Hz	Voltage	200-230/460 V
Current	SF 9.8-9.6/4.8 A	Speed	3450 rpm
Service Factor	1.15	Phase	3
Efficiency	82.8 %	Duty	Continuous
Insulation Class	B	Frame	N56J
Enclosure	Drip Proof	Thermal Protection	No Protection
Ambient Temperature	40 °C	UL	Recognized
CSA	Y	CE	N
Number of Speeds	1		

Technical Specifications

Electrical Type	Polyphase, Induction Type, Single Or Dual Voltage	Starting Method	Across The Line
Poles	2	Rotation	Reversible Clockwise
Mounting	Round	Drive End Bearing	Ball
Opp Drive End Bearing	Ball	Frame Material	Rolled Steel
Shaft Type	Threaded	Overall Length	12.85 in
Frame Length	7.25 in	Shaft Diameter	0.625 in
Shaft Extension	2.60 in		
Outline Drawing	12686-003	Connection Drawing	18304024.PCX

This is an uncontrolled document once printed or downloaded and is subject to change without notice. Date Created:11/28/2022

REV	ECO	REV BY	DATE	APPD	DATE
C	0025552	L.HEREDIA	05-01-2012	M.AVILA	05-01-2012

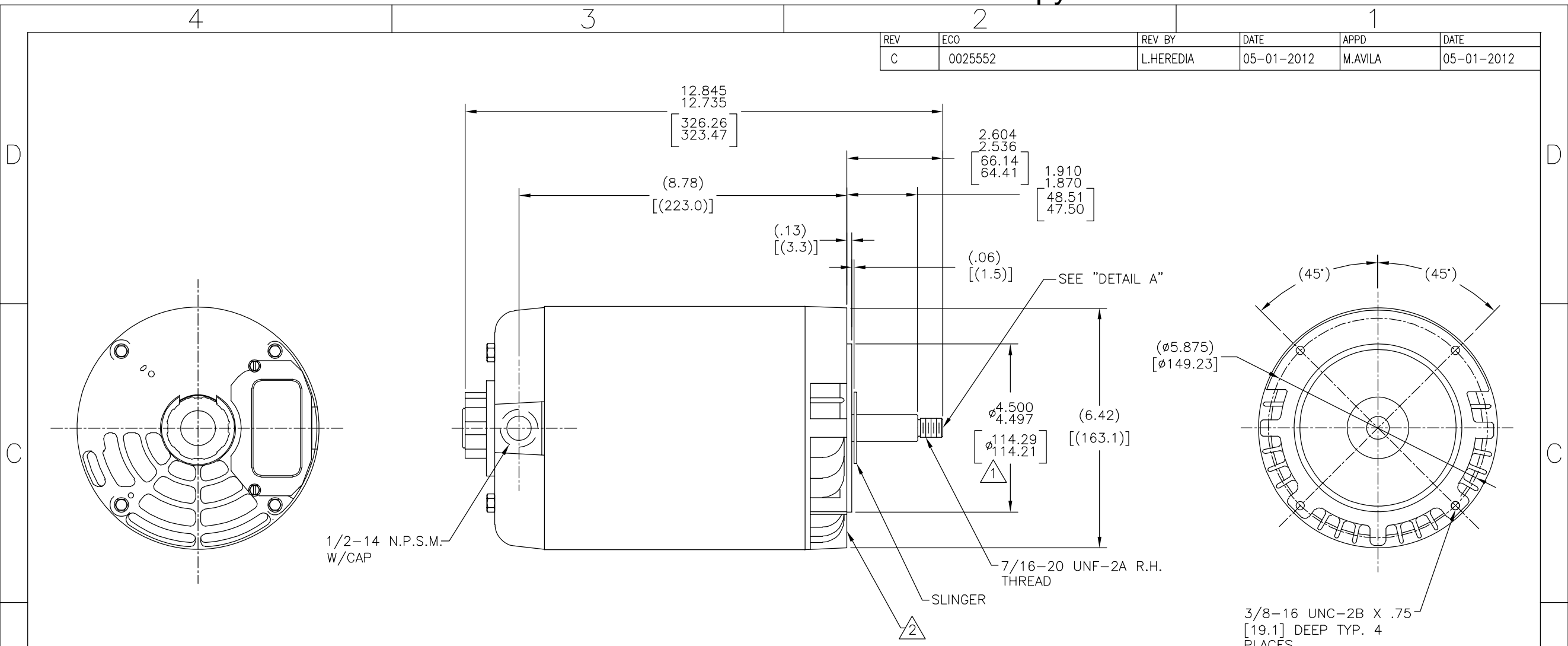

NAMEPLATE DATA
MODEL: 182595 CUST. P/N: H734 HP: 3.0 SF: 1.15 ROT: RCW RPM: 3450 TYPE: SC CODE: F FRAME: N 56 J VOLTS: 200-230/460 AMPS: SF 9.8-9.6/4.8 MAX AMPS: PH: 3 HZ: 60 INS: B AMB: 40°C DUTY: CONT

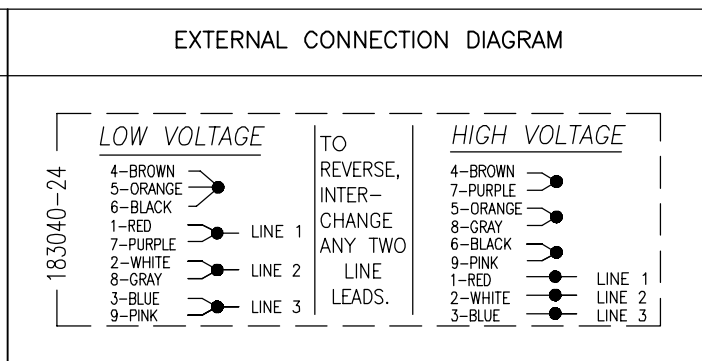

PERFORMANCE CURVE NO.	APPROVED SAMPLE OR REF. MODEL		
14817921			
UL COMPONENT			
FILE#	CCN#	FILE#	CLASS#
E44549	PRGY2	LR4642	4211-01
ENCLOSURE: ODP		CUSTOMER: DISTRIBUTION	

- NOTES:
- 1. PILOT DIAMETER IS CONCENTRIC WITH SHAFT CENTERLINE WITHIN .004 T.I.R.
 - 2. FACE OF MOUNTING FLANGE IS PERPENDICULAR TO SHAFT CENTERLINE WITHIN .004 T.I.R.
 - 3. SHAFT RUNOUT NOT TO EXCEED .002 T.I.R.
 - 4. FOR THREADED SHAFT EXT. MATING PARTS SHOULD BE RELIEVED ONE THREAD TO CLEAR FILLET.
 - 5. FOR THREADER SHAFT EXT. ECCENTRICITY OF THREADED PORTION OF SHAFT IS HELD WITHIN .004 TOTAL GAGE READING WITH THE INDICATOR ON O.D. OF GROUND RING AS SHOWN. THE GAGE BEING STATIONARY WITH RESPECT TO THE ROTOR.
 - 6. END PLAY NOT TO EXCEED .010 MEASURED WITH NO THRUST

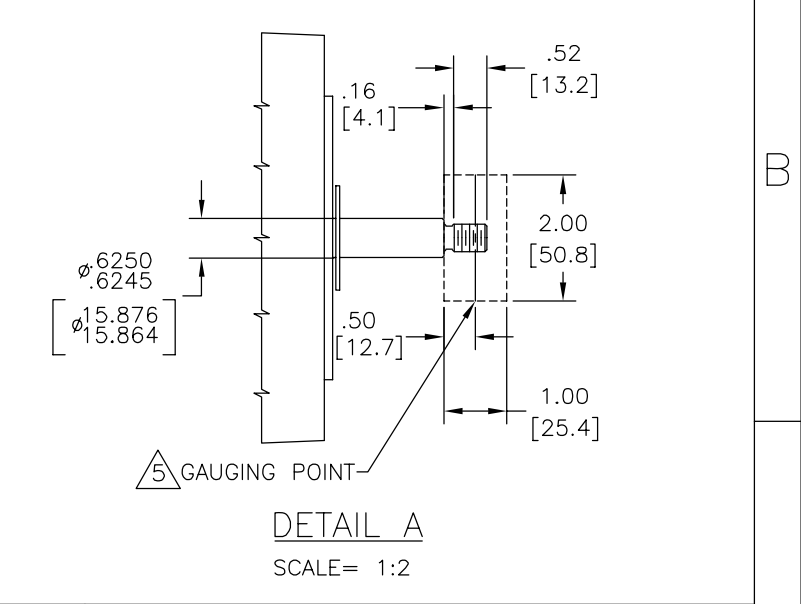

GEOMETRIC CHARACTERISTICS & SYMBOLS
□ FLATNESS — STRAIGHTNESS ∠ ANGULARITY ⊥ PERPENDICULARITY (SQUARENESS) // PARALLELISM ○ ROUNDNESS (CIRCULARITY) ⌀ CYLINDRICITY △ PROFILE OF ANY SURFACE ∩ PROFILE OF ANY LINE ↗ RUNOUT ⊕ TRUE POSITION ⊙ CONCENTRICITY = SYMMETRY

UNLESS OTHERWISE SPECIFIED DIM. TOLERANCES ARE AS FOLLOWS:
INCH X XX XXX XXXX ±.1 ±.02 ±.005 ±.0005 mm ±0.5 ±0.13 ±0.013 ANG. ±.50 DEG REMOVE BURRS & BREAK SHARP EDGES: INCH .003-.015 mm 0.1-0.4 CORNER FILLETS TO: INCH .020 mm 0.5 MACHINE SURFACES: INCH 125 mm 3.2

DR BY: KHR APPD: 09-07-2005 EDS DATE 11-11-2011 FORMAT REV G
--

THIRD ANGLE PROJECTION

CONFIDENTIAL: THIS DRAWING AND ITS INFORMATION ARE THE EXCLUSIVE AND CONFIDENTIAL PROPERTY OF REGAL-BELOIT CORPORATION AND ARE NOT TO BE DISCLOSED, DUPLICATED, DISTRIBUTED OR OTHERWISE USED WITHOUT THE WRITTEN CONSENT OF REGAL-BELOIT CORPORATION. -ALL RIGHTS RESERVED.

DESCRIPTION	
MODEL-CFHP-56FR OUTLINE	
SIZE C	DWG NO 12686-003
SCALE NONE	SHEET 1

REVISION:	ECO	REVISADO POR:	FECHA:	APROBADO POR:	FECHA:
C	0025552	L.HEREDIA	05-01-2012	M.AVILA	05-01-2012

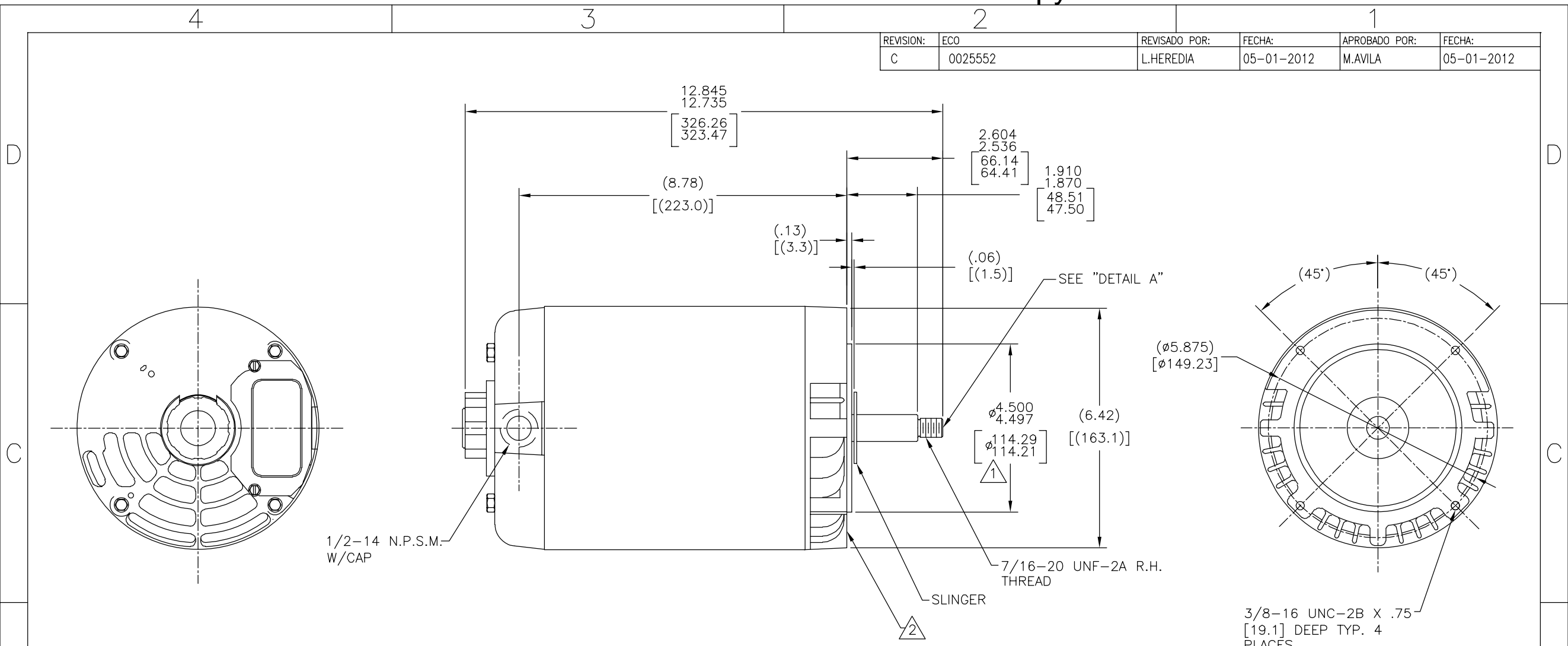

NAMEPLATE DATA
MODEL: 182595 CUST. P/N: H734 HP: 3.0 SF: 1.15 ROT: RCW RPM: 3450 TYPE: SC CODE: F FRAME: N 56 J VOLTS: 200-230/460 AMPS: SF 9.8-9.6/4.8 MAX AMPS: PH: 3 HZ: 60 INS: B AMB: 40°C DUTY: CONT

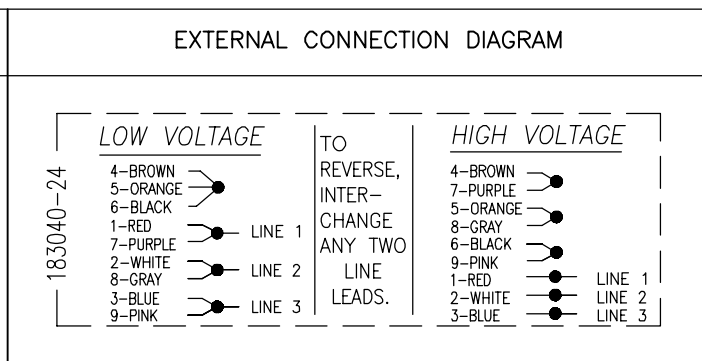

PERFORMANCE CURVE NO.	APPROVED SAMPLE OR REF. MODEL		
14817921			
UL COMPONENT	CSA		
FILE#	CCN#	FILE#	CLASS#
E44549	PRGY2	LR4642	4211-01
ENCLOSURE: ODP		CUSTOMER: DISTRIBUTION	

NOTES:

1. PILOT DIAMETER IS CONCENTRIC WITH SHAFT CENTERLINE WITHIN .004 T.I.R.

2. FACE OF MOUNTING FLANGE IS PERPENDICULAR TO SHAFT CENTERLINE WITHIN .004 T.I.R.

3. SHAFT RUNOUT NOT TO EXCEED .002 T.I.R.

4. FOR THREADED SHAFT EXT. MATING PARTS SHOULD BE RELIEVED ONE THREAD TO CLEAR FILLET.

5. FOR THREADER SHAFT EXT. ECCENTRICITY OF THREADED PORTION OF SHAFT IS HELD WITHIN .004 TOTAL GAGE READING WITH THE INDICATOR ON O.D. OF GROUND RING AS SHOWN. THE GAGE BEING STATIONARY WITH RESPECT TO THE ROTOR.

6. END PLAY NOT TO EXCEED .010 MEASURED WITH NO THRUST

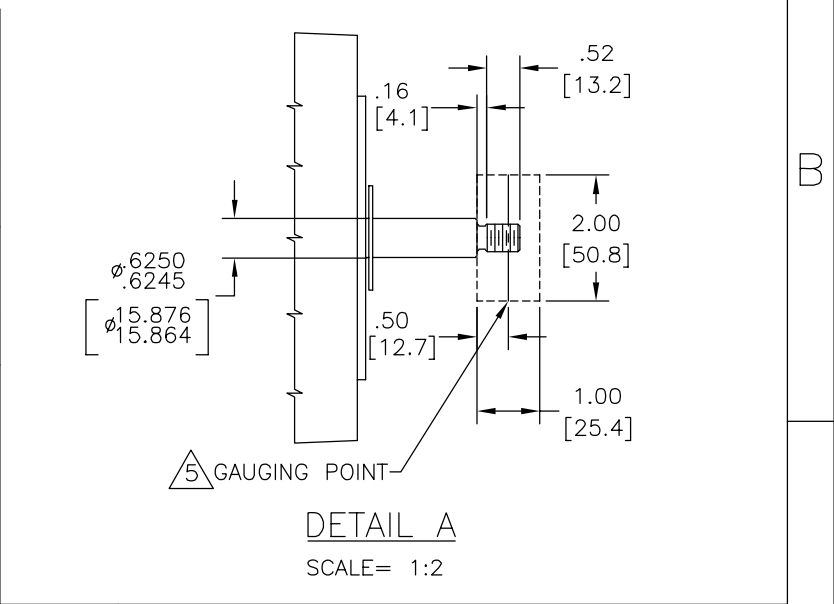

CARACTERISTICAS DE GEOMETRIA Y SIMBOLOS
□ PLANICIDAD — RECTITUD < ANGULARIDAD ⊥ PERPENDICULARIDAD (A ESCUADRA) // PARALELISMO ○ REDONDEZ (CIRCULARIDAD) ∅ CILINDRICIDAD △ PERFIL DE CUALQUIER SUPERFICIE ∩ PERFIL DE CUALQUIER LINEA ↗ VARIACION ⊕ POSICION REAL ⊙ CONCENTRICIDAD = SIMETRIA

ASME Y14.5M 1994
DIMS METRICAS MOSTRADAS [PARENTESIS]

A MENOS QUE SE ESPECIFIQUE DE OTRA MANERA, LAS TOLERANCIAS DE LAS DIMS; SON LAS SIGUIENTES:
PULG ±.1 ±.02 ±.005 ±.0005 mm ±0.5 ±0.13 ±0.013 ANG. ±50 GRADOS ELIMINAR REBABAS Y ORILLAS FILOSAS DEL BORDE. PULG .003-.015 mm 0.1-0.4 FILETEAR ESQUINA: PULG .020 mm 0.5 MAQUINAR SUPERFICIES PULG 125 mm 3.2

DIBUJADO POR: KHR	09-07-2005
APROBADO POR:	
TERCER ANGULO DE PROYECCION	FECHA EDS: 11-11-2011 REV. FORMATO: G
CONFIDENCIAL: ESTE DIBUJO Y SU INFORMACION SON PROPIEDAD DE USO EXCLUSIVO Y CONFIDENCIAL DE REGAL-BELOIT CORPORATION. Y NO DEBERAN SER REVELADOS, DUPLICADOS, DISTRIBUIDOS O USARSE DE OTRA MANERA SIN EL CONSENTIMIENTO ESCRITO DE REGAL-BELOIT CORPORATION. -TODOS LOS DERECHOS RESERVADOS.	

DESCRIPCION: MODEL-CFHP-56FR OUTLINE	
TAMAÑO: C	NUMERO DE DIBUJO: 12686-003
ESCALA: NONE	HOJA: 1

4

3

2

1

版本	ECO	编制	日期	批准	日期
C	0025552	L.HEREDIA	05-01-2012	M.AVILA	05-01-2012

D

D

C

C

B

B

A

A

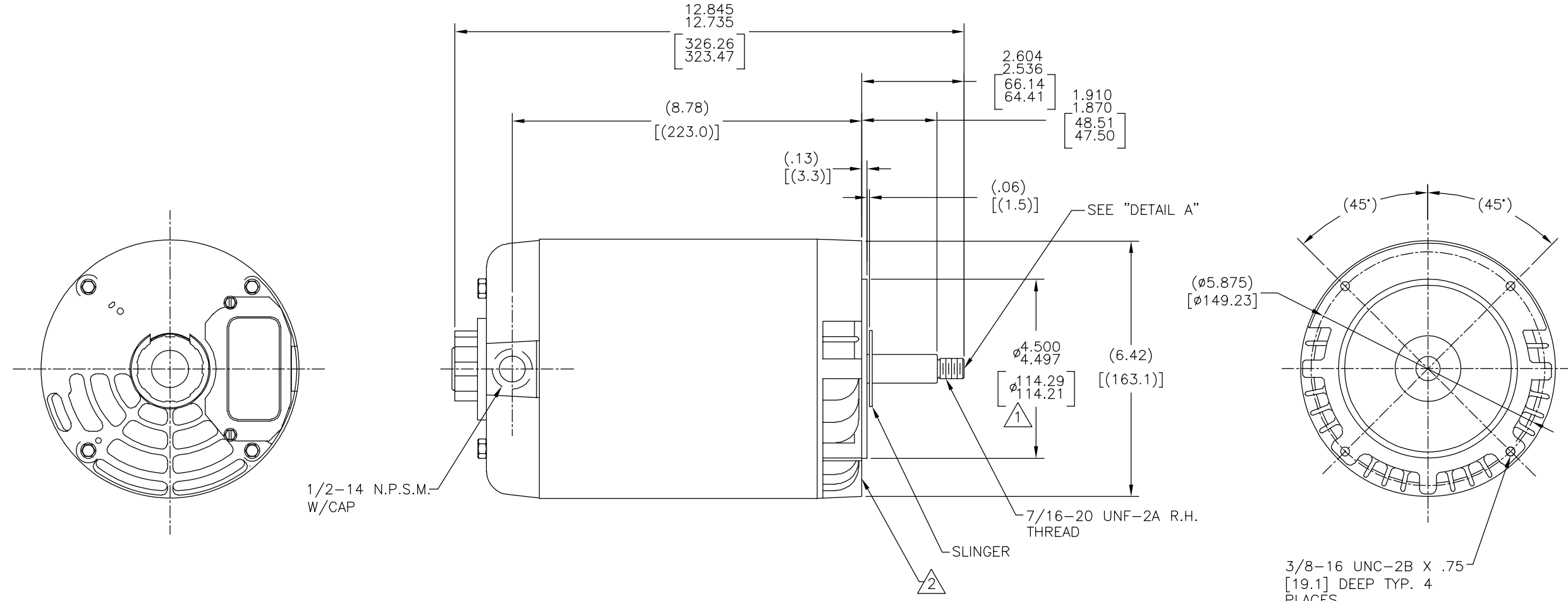

NAMEPLATE DATA
MODEL: 182595 CUST. P/N: H734 HP: 3.0 SF: 1.15 ROT: RCW RPM: 3450 TYPE: SC CODE: F FRAME: N 56 J VOLTS: 200-230/460 AMPS: SF 9.8-9.6/4.8 MAX AMPS: PH: 3 HZ: 60 INS: B AMB: 40°C DUTY: CONT

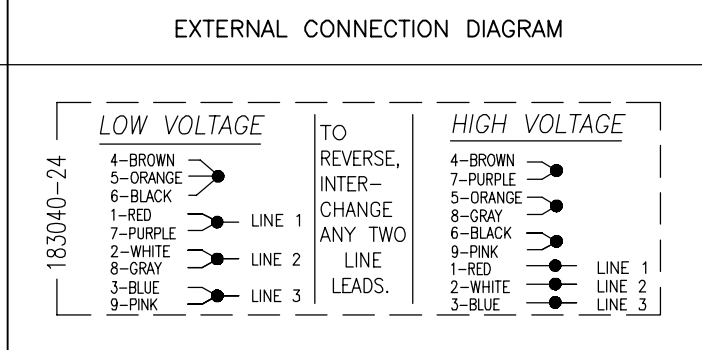

PERFORMANCE CURVE NO.	APPROVED SAMPLE OR REF. MODEL		
14817921			
UL COMPONENT	CSA		
FILE#	CCN#	FILE#	CLASS#
E44549	PRGY2	LR4642	4211-01
ENCLOSURE: ODP		CUSTOMER: DISTRIBUTION	

- NOTES:
- PILOT DIAMETER IS CONCENTRIC WITH SHAFT CENTERLINE WITHIN .004 T.I.R.
 - FACE OF MOUNTING FLANGE IS PERPENDICULAR TO SHAFT CENTERLINE WITHIN .004 T.I.R.
 - SHAFT RUNOUT NOT TO EXCEED .002 T.I.R.
 - FOR THREADED SHAFT EXT. MATING PARTS SHOULD BE RELIEVED ONE THREAD TO CLEAR FILLET.
 - FOR THREADER SHAFT EXT. ECCENTRICITY OF THREADED PORTION OF SHAFT IS HELD WITHIN .004 TOTAL GAGE READING WITH THE INDICATOR ON O.D. OF GROUND RING AS SHOWN. THE GAGE BEING STATIONARY WITH RESPECT TO THE ROTOR.
 - END PLAY NOT TO EXCEED .010 MEASURED WITH NO THRUST

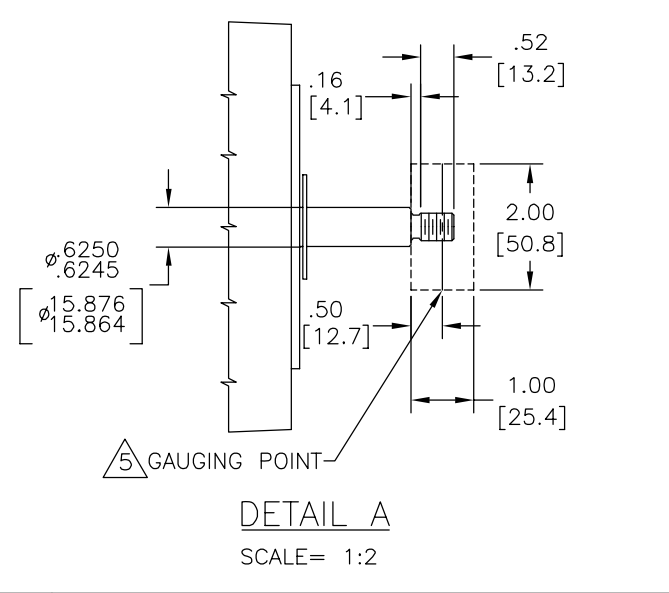

形位公差 □ 平面度 — 直线度 ∠ 倾斜度 ⊥ 垂直度 // 平行度 ○ 圆度 ⊙ 圆柱度 △ 面轮廓度 ⊖ 线轮廓度 ⤴ 圆跳动 ⊕ 位置度 ⊗ 同轴度 ≡ 对称度	除另有注明 尺寸公差如下: 英寸 X XX XXX XXXX 毫米 ±.1 ±.02 ±.005 ±.0005 毫米 ±0.5 ±0.13 ±0.013 角度 ±.50 度 清理毛刺和尖棱 英寸 .003-.015 毫米 0.1-0.4 内圆角 英寸 .020 毫米 0.5 表面粗糙度 英制 125 米制 3.2
---	--

绘图: KHR	09-07-2005
批准:	
第三角投影	图纸格式发布日期 11-11-2011 图纸格式版本 G
机密: 本图纸及相关信息所有权归REGAL-BELOIT CORPORATION. 未经REGAL-BELOIT CORPORATION书面授权, 不得泄露、复制、传播或作其他用途。—版权所有	

名称: MODEL-CFHP-56FR OUTLINE	
图幅: C	图号: 12686-003
比例: NONE	页号: 1

4

3

2

1