

PRODUCT INFORMATION PACKET



Model No: OCA1016
Catalog No: OCA1016

OEM Replacement Motor, 1/6 HP, 1 Ph, 60 Hz, 208-230 V, 1075 RPM, 1 Speed, 48 Frame, ENCLOSED



Regal and Century are trademarks of Regal Rexnord Corporation or one of its affiliated companies.
©2022 Regal Rexnord Corporation, All Rights Reserved. MC017097E





Nameplate Specifications

Output HP	1/6 Hp	Output KW	0.13 kW
Frequency	60 Hz	Voltage	208-230 V
Current	0.80-0.95 A	Speed	1075 rpm
Service Factor	1	Phase	1
Duty	Air Over	Insulation Class	B
Frame	48Y	Enclosure	Totally Enclosed
Thermal Protection	Automatic	Ambient Temperature	40 °C
UL	Recognized	CSA	Y
CE	N	Number of Speeds	1

Technical Specifications

Electrical Type	Permanent Split Capacitor	Starting Method	Across The Line
Poles	6	Rotation	Counterclockwise Lead End
Mounting	Round Belly Band	Motor Orientation	Vertical Shaft Down
Drive End Bearing	Sleeve	Opp Drive End Bearing	Sleeve
Frame Material	Rolled Steel	Shaft Type	Flat
Overall Length	7.30 in	Frame Length	3.00 in
Shaft Diameter	0.500 in	Shaft Extension	3.7 in
Outline Drawing	OCA1016-S01	Connection Drawing	614131-205

This is an uncontrolled document once printed or downloaded and is subject to change without notice. Date Created:11/29/2022

4 3 2 1

REV	ECO	REV BY	DATE	APPD	DATE
C	0025553	F. MORENO	05-01-2012	M. AVILA	05-01-2012

GENERAL INFORMATION:

SHAFT RUNOUT: .001[.02] T.I.R. PER INCH LENGTH OF EXTENSION

END PLAY: .010[.25] TO .063[1.60]

BEARINGS: SLEEVE

MOUNTING POSITION: VERTICAL SHAFT DOWN

ELECTRICAL DATA:

OVERLOAD PROTECTOR: AUTOMATIC RESET (T.I. 7AM 036)

LEADS: NO. 18 GA., .06[1.5] THK., PVC 105' INSUL

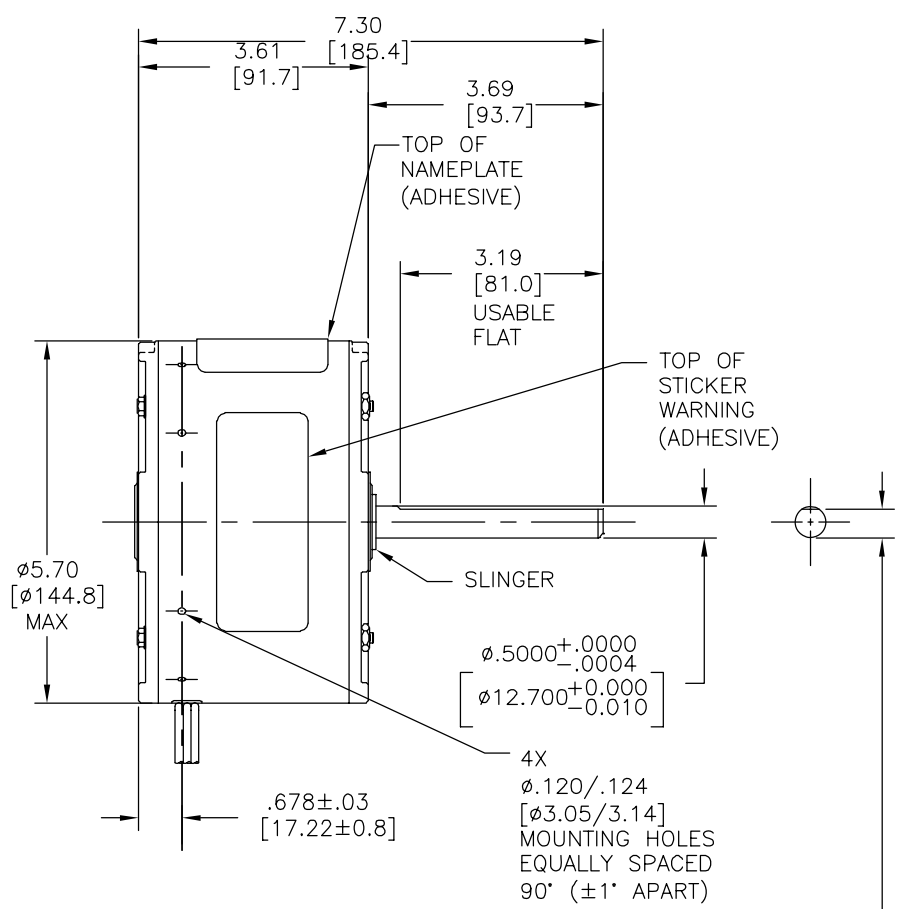
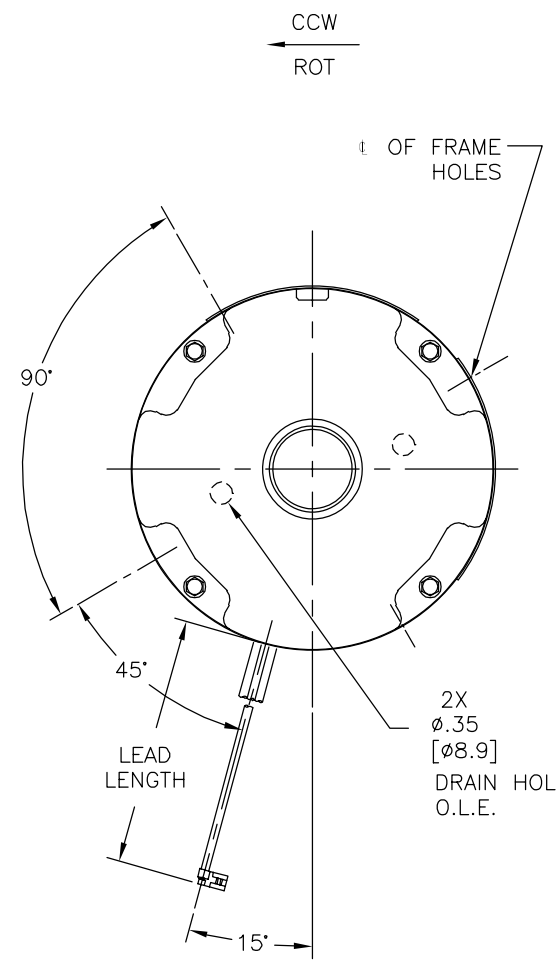

NAMEPLATE DATA:

HP: MODEL NO.: F48V30A01
 P/N: OCA1016
 1/6
 ROT.: CCWLE
 1075
 TYPE: UF
 FRAME: 48Y
 VOLTS: 208-230
 INS.: 1
 AMPS: 0.80-0.95
 60
 B
 AMB.: 40° C
 DUTY: AIR OVER
 CAP.: 3 MFD/370V
 ENCL: ENCLOSED
 UL LOGO
 CSA LOGO
 THERMALLY PROTECTED

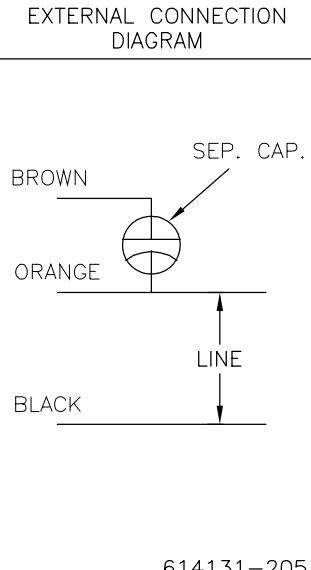

614131-205

BROWN	39.0/42.0 [990/1066]	.25[6.35] FLAG
ORANGE	39.0/42.0 [990/1066]	.25[6.35] FLAG
BLACK	39.0/42.0 [990/1066]	.25[6.35] FLAG
COLOR	LENGTH	TERMINAL OR STRIP LENGTH

MAIN FRAME - OLE	ENCLOSED
END FRAME - OLE	ENCLOSED
MAIN FRAME - LE	ENCLOSED
END FRAME - LE	ENCLOSED

CUSTOMER	DIST. SVCS.
----------	-------------

PERFORMANCE CURVE NO.	TORQUE @ 1075 RPM (25°C)	APPROVED SAMPLE	UL COMPONENT FILE #	CCN #	CSA FILE #	CLASS #
C32346	13.0 OZ. FT.	0442987B	E46412	PRGY2	LR43341	4211-01

GEOMETRIC CHARACTERISTICS & SYMBOLS

- ▮ FLATNESS
- STRAIGHTNESS
- ∠ ANGULARITY
- ⊥ PERPENDICULARITY (SQUARENESS)
- ∥ PARALLELISM
- ROUNDNESS (CIRCULARITY)
- ⊘ CYLINDRICITY
- △ PROFILE OF ANY SURFACE
- ∧ PROFILE OF ANY LINE
- ↑ RUNOUT
- ⊕ TRUE POSITION
- ◎ CONCENTRICITY
- ≡ SYMMETRY

ASME Y14.5M 1994

REGAL-BELOIT CORPORATION (RBC) PROVIDES TECHNICAL ASSISTANCE TO OUR CUSTOMERS IN SEVERAL AREAS. SINCE RBC DOES NOT RECEIVE ALL DATA CONCERNING THE USE AND APPLICATION OF THE MOTOR, THE SUITABILITY OF THE MOTOR FOR THE APPLICATION MUST BE DETERMINED BY THE CUSTOMER.

DIMENSIONS WITHOUT TOLERANCES ARE FOR REFERENCE ONLY.

DR BY: J.MENA 09-01-2011

APPD: H.SANCHEZ 09-01-2011

EDS DATE 11-11-2011
 FORMAT REV G

THIRD ANGLE PROJECTION

CONFIDENTIAL: THIS DRAWING AND ITS INFORMATION ARE THE EXCLUSIVE AND CONFIDENTIAL PROPERTY OF REGAL-BELOIT CORPORATION AND ARE NOT TO BE DISCLOSED, DUPLICATED, DISTRIBUTED OR OTHERWISE USED WITHOUT THE WRITTEN CONSENT OF REGAL-BELOIT CORPORATION. -ALL RIGHTS RESERVED.

REGAL-BELOIT CORPORATION

DESCRIPTION: MODEL-RFHP-48FR OUTLINE

SIZE: C DWG NO: OCA1016

SCALE: NONE SHEET: 1

4 3 2 1

INFORMACION GENERAL:

OSCILACION DE FLECHA: .001[.02] L.T.I. POR PULG. DE LONG. DE EXTENSION

JUEGO AXIAL: .010[.25] A .063[1.60]

BALEROS: MANGA

POSICION DEL MONTAJE: FLECHA EN VERTICAL PARA ABAJO

INFORMACION ELECTRICA:

PROTECTOR DE SOBRECARGA: REINICIO AUTOMATICO (T.I. 7AM 036)

CABLES: CALIBRE NO. 18., .06[1.5] DE ESPESOR., AISLANTE PVC 105'

INFORMACION DE ETIQUETA: DIAGRAMA DE CONEXION EXTRNA

HP:
 MODEL NO.: F48V30A01
 P/N: OCA1016
 1/6
 ROT.: CCWLE
 1075
 TYPE: UF
 FRAME: 48Y
 VOLTS: 208-230
 INS.: 1
 AMPS: 0.80-0.95
 60
 B
 AMB.: 40° C
 DUTY: AIR OVER
 CAP.: 3 MFD/370V
 ENCL: ENCLOSED
 UL LOGO

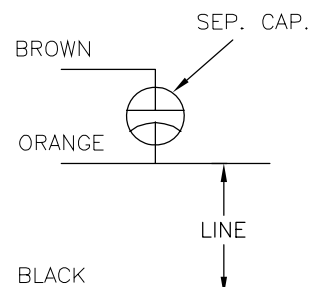

CSA CURVED TORSION @ 1075 MUESTRA COMPONENTE UL CSA
 FUNCTIONAL PROTECTED (25°C) APROBADA #ARCHIVO CCN # #ARCHIVO CLASE #
 614131-205

C32346 13.0 OZ. FT. 0442987B E46412 PRGY2 LR43341 4211-01

CARACTERISTICAS DE GEOMETRIA Y SIMBOLOS
 ▽ PLANICIDAD
 — RECTITUD
 ∠ ANGULARIDAD
 ⊥ PERPENDICULARIDAD (A ESCUADRA)
 // PARALELISMO
 ○ REDONDEZ (CIRCULARIDAD)
 ⌀ CILINDRICIDAD
 △ PERFIL DE CUALQUIER SUPERFICIE
 ▽ PERFIL DE CUALQUIER LINEA
 ↑ VARIACION
 ⊕ POSICION REAL
 ⊙ CONCENTRICIDAD
 ≡ SIMETRIA
 ASME Y14.5M 1994

REGAL-BELOIT CORPORATION (RBC) PROVEE ASISTENCIA TECNICA A NUESTROS CLIENTES EN VARIAS AREAS. DESDE QUE RBC NO RECIBE TODOS LOS DATOS EN RELACION AL USO Y A LA APLICACION DEL MOTOR, LA APLICACION ADECUADA DEL MOTOR DEBE SER DETERMINADA POR EL CLIENTE.

DIMENSIONES SIN TOLERANCIA SON DE REFERENCIA SOLAMENTE

DIBUJADO POR: J.MENA 09-01-2011
 APROBADO POR: H.SANCHEZ 09-01-2011
 TERCER ANGULO DE PROYECCION

CONFIDENCIAL: ESTE DIBUJO Y SU INFORMACION SON PROPIEDAD DE USO EXCLUSIVO Y CONFIDENCIAL DE REGAL-BELOIT CORPORATION. Y NO DEBERAN SER REVELADOS, DUPLICADOS, DISTRIBUIDOS O USARSE DE OTRA MANERA SIN EL CONSENTIMIENTO ESCRITO DE REGAL-BELOIT CORPORATION. -TODOS LOS DERECHOS RESERVADOS.

REGAL-BELOIT CORPORATION

DESCRIPCION: MODEL-RFHP-48FR OUTLINE
 TAMAÑO: C NUMERO DE DIBUJO: OCA1016
 ESCALA: NONE HOJA: 1

REVISION:	ECO	REVISADO POR:	FECHA:	APROBADO POR:	FECHA:
C	0025553	F. MORENO	05-01-2012	M. AVILA	05-01-2012

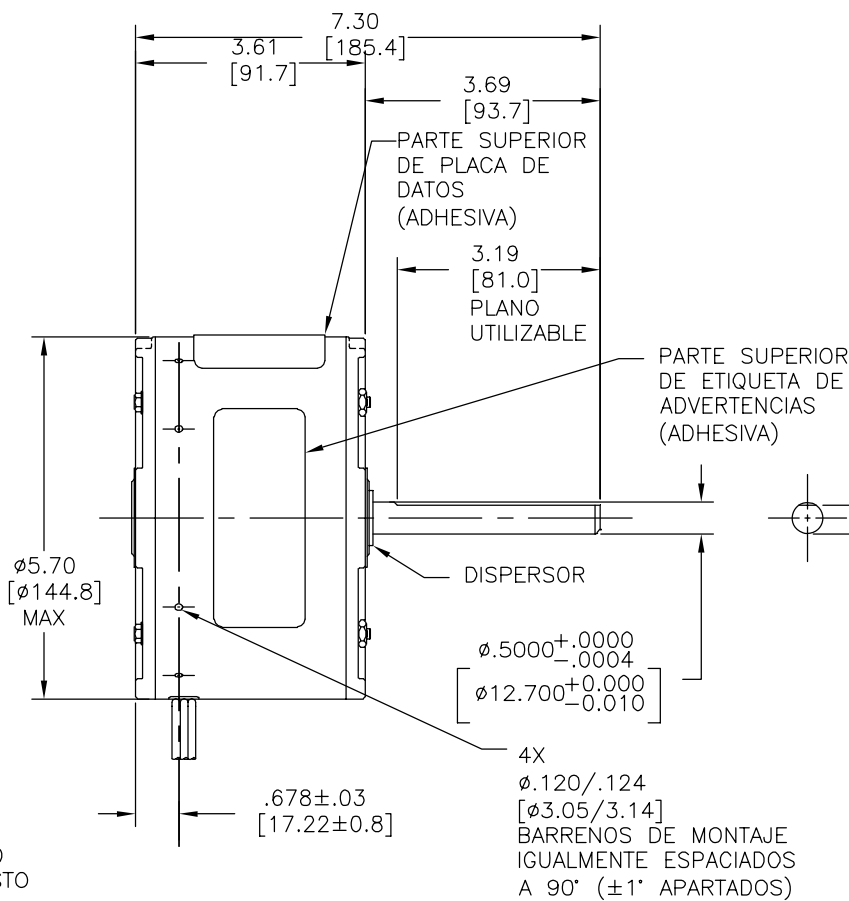
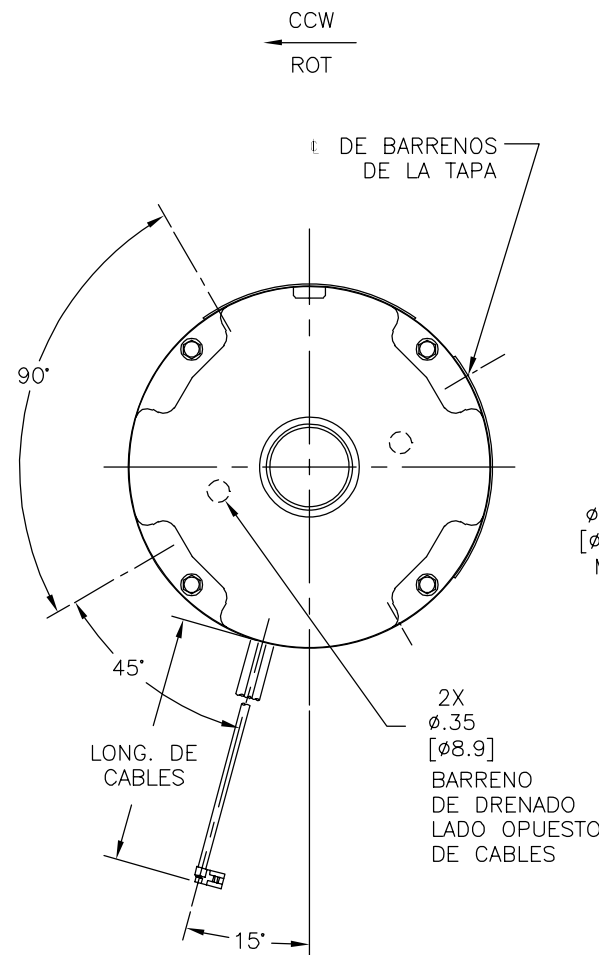

.453±.005 [11.51±0.13] PLANO

CAFE	.25[6.35]	BANDERA
ANARANJADO	39.0/42.0 [990/1066]	BANDERA
NEGRO	39.0/42.0 [990/1066]	BANDERA
COLOR	39.0/42.0 [990/1066]	TERMINAL O LONGITUD DE DESFORRE
INFORMACION DE CABLES		

CARCASA - LOC	CERRADO
TAPA - LOC	CERRADO
CARCASA - LC	CERRADO
TAPA - LC	CERRADO
TIPO DE MOTOR	

CLIENTE

DIST. SVCS.

总技术要求:

4

3

2

1

轴跳动:

端部窜动量

轴承:

安装位置:

电气数据:

过载保护:

引线:

版本	ECO	编制	日期	批准	日期
C	0025553	F. MORENO	05-01-2012	M. AVILA	05-01-2012

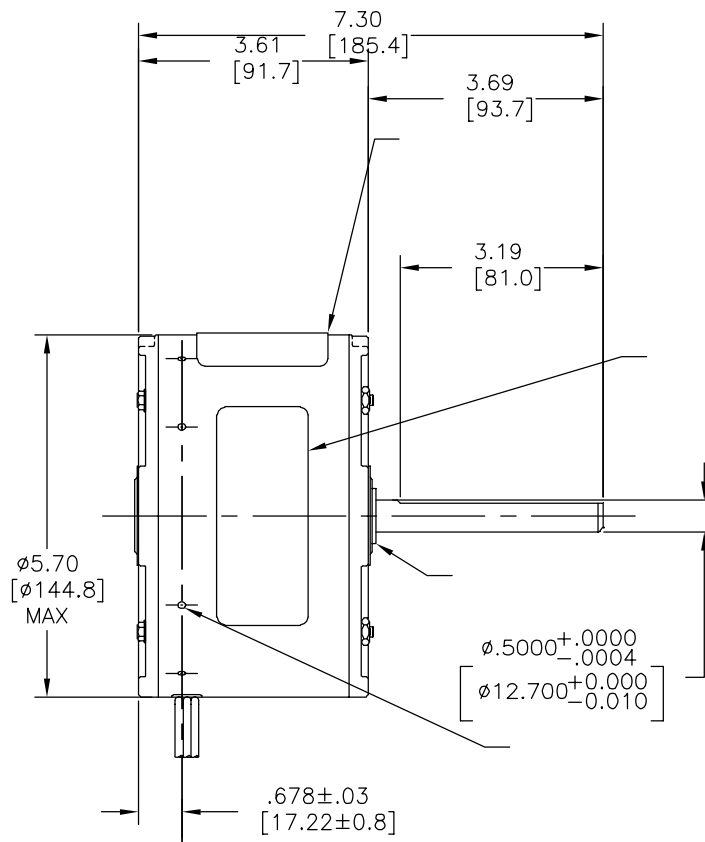
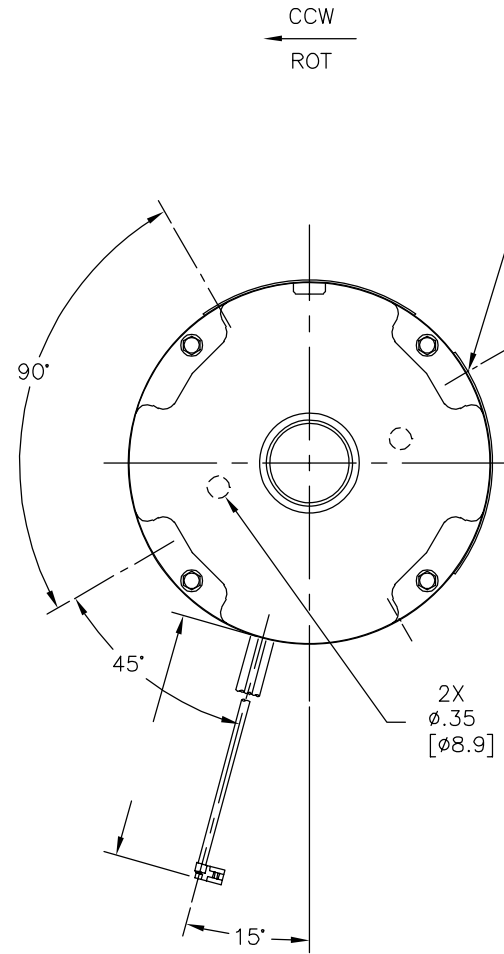

.453±.005 [11.51±0.13]

铭牌数据 外部数据线

HP:
MODEL NO.: F48V30A01
BMT. P/N: OCA1016
1/6
ROT.: CCWLE
1075
TYPE: UF
FRAME: 48Y
VOLTS: 208-230
INS.: 1
AMPS: 0.80-0.95
60
B
AMB.: 40° C
DUTY: AIR OVER
CAP.: 3 MFD/370V
ENCL: ENCLOSED
UL LOGO
CSA LOGO
THERMALLY PROTECTED (5° C)

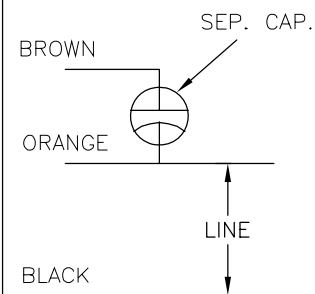

CSA LOGO	CSA	CSA	CSA	CSA	CSA	CSA	CSA
零件号	零件号	零件号	零件号	零件号	零件号	零件号	零件号
614131-205	614131-205	614131-205	614131-205	614131-205	614131-205	614131-205	614131-205
C32346	13.0 OZ. FT.	0442987B	E46412	PRGY2	LR43341	4211-01	

	39.0/42.0 [990/1066]	
	39.0/42.0 [990/1066]	
颜色	39.0/42.0 [990/1066]	端子或剥线长度
	39.0/42.0 [990/1066]	

无引线端机壳	
无引线端盖	
有引线端机壳	
有引线端盖	
密封鞋	

用户

DIST. SVCS.

- 形位公差
- 平面度
- 直线度
- ∠ 倾斜度
- ⊥ 垂直度
- ∥ 平行度
- 圆度
- 圆柱度
- 面轮廓度
- 线轮廓度
- ⊕ 圆跳动
- ⊕ 位置度
- ⊕ 同轴度
- ≡ 对称度

ASME Y14.5M 1994

REGAL-BELOIT CORPORATION
(RBC) 在个别领域为客户
提供技术支持。鉴于 RBC
未收到任何涉及电机使用和
应用环境的数据，电机的适用性
由客户自己决定。

未注公差尺寸仅供参考。

绘图: J.MENA 09-01-2011
批准: H.SANCHEZ 09-01-2011
第三角投影
图纸格式发布日期 11-11-2011
图纸格式版本 G
机密: 本图纸及相关信息所有权归REGAL-BELOIT CORPORATION
未经REGAL-BELOIT CORPORATION书面授权, 不得泄露、
复制、传播或作其他用途。—版权所有



名称
**MODEL-RFHP-48FR
OUTLINE**

图幅 C 图号 OCA1016

比例 NONE 页号 1

4

3

2

1

REV	ECO	REV BY	DATE	APPD	DATE
B	ECO-0021846	jrupert	09-08-2011	jrupert	09-08-2011

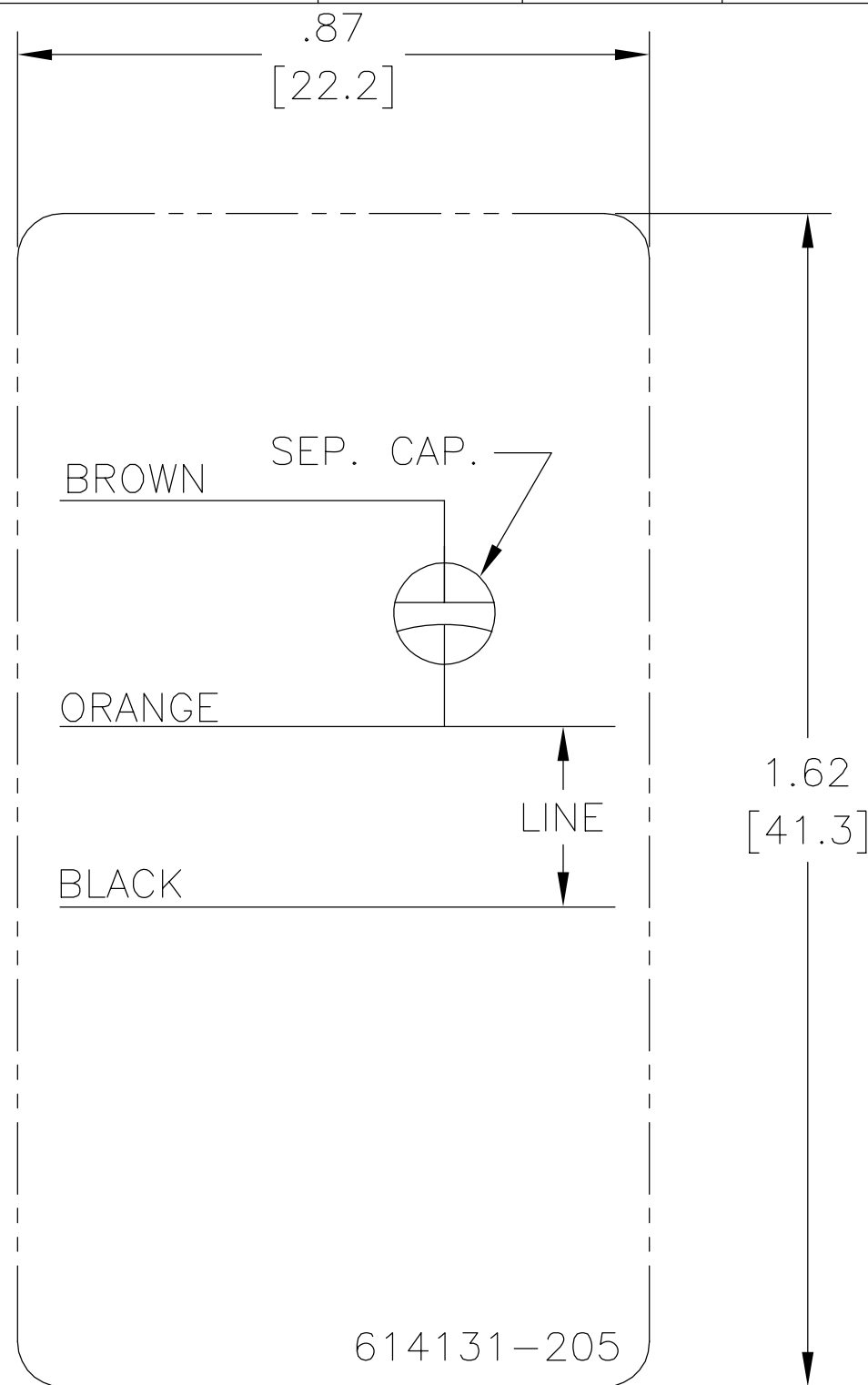

NOTES:

1. FOR USE WITH 614129 NAMEPLATE BLANK
2. — — — — — INDICATES DIMENSION LIMITS
3. DIE TO BE MADE FROM MASTER SUPPLIED BY A. O. SMITH CORPORATION
4. DIE MUST PRODUCE A LEGIBLE IMPRESSION.

GEOMETRIC CHARACTERISTICS & SYMBOLS

- ▭ FLATNESS
- STRAIGHTNESS
- ∠ ANGULARITY
- ⊥ PERPENDICULARITY (SQUARENESS)
- // PARALLELISM
- ROUNDNESS (CIRCULARITY)
- ⊘ CYLINDRICITY
- △ PROFILE OF ANY SURFACE
- ∩ PROFILE OF ANY LINE
- ↑ RUNOUT
- ⊕ TRUE POSITION
- ◎ CONCENTRICITY
- ≡ SYMMETRY

UNLESS OTHERWISE SPECIFIED
DIM. TOLERANCES ARE AS FOLLOWS:

INCH	±.1	±.02	±.005	±.0005
mm	±0.5	±0.13	±0.013	

ANG. ±.50 DEG

REMOVE BURRS & BREAK SHARP EDGES:

INCH	.003-.015	mm	0.1-0.4
------	-----------	----	---------

CORNER FILLETS TO:

INCH	.020	mm	0.5
------	------	----	-----

MACHINE SURFACES:

INCH	125	mm	3.2
------	-----	----	-----

METRIC DIMS. SHOWN IN [BRACKETS]

DR BY:	jrupert	09-08-2011
APPD:	jrupert	09-08-2011
THIRD ANGLE PROJECTION		EDS DATE 02-22-2008 FORMAT REV F
CONFIDENTIAL: THIS DRAWING AND ITS INFORMATION ARE THE EXCLUSIVE AND CONFIDENTIAL PROPERTY OF A.O. SMITH CORP. AND ARE NOT TO BE DISCLOSED, DUPLICATED, DISTRIBUTED OR OTHERWISE USED WITHOUT THE WRITTEN CONSENT OF A.O. SMITH CORP. -ALL RIGHTS RESERVED. ASME Y14.5M 1994		

 AC Smith innovation has a name.		ELECTRICAL PRODUCTS COMPANY A DIVISION OF A. O. SMITH CORPORATION	
DESCRIPTION CONN DIAGRAM-NAMEPLATE			
SIZE A	DWG NO 614131-205		
SCALE NONE			SHEET 1

REVISION:	ECO	REVISADO POR:	FECHA:	APROBADO POR:	FECHA:
B	ECO-0021846	jrupert	09-08-2011	jrupert	09-08-2011

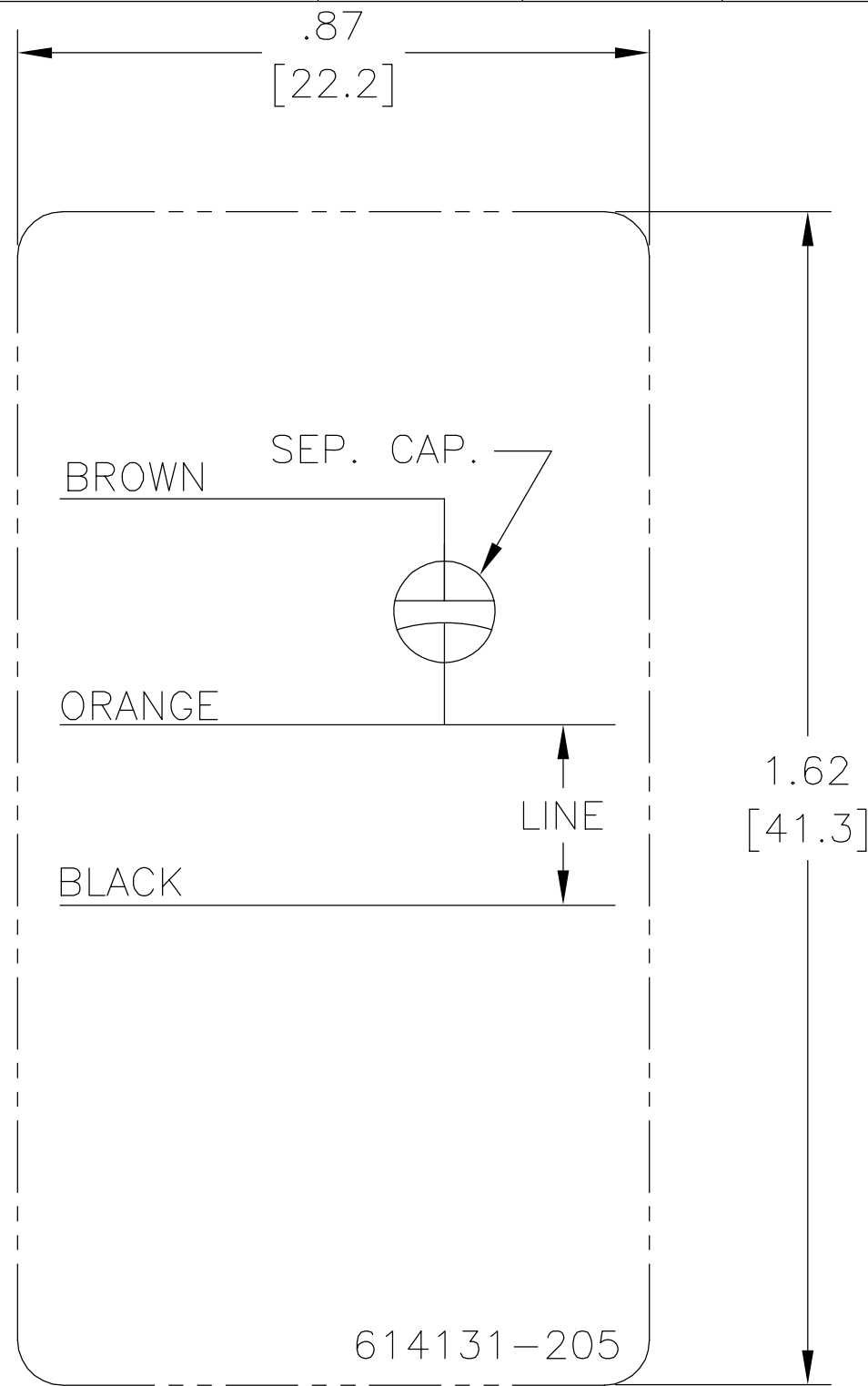

NOTES:

1. FOR USE WITH 614129 NAMEPLATE BLANK
2. ——— ———— INDICATES DIMENSION LIMITS
3. DIE TO BE MADE FROM MASTER SUPPLIED BY A. O. SMITH CORPORATION
4. DIE MUST PRODUCE A LEGIBLE IMPRESSION.

CARACTERISTICAS DE GEOMETRIA Y SIMBOLOS ▽ PLANICIDAD — RECTITUD ∠ ANGULARIDAD ⊥ PERPENDICULARIDAD (A ESCUADRA) // PARALELISMO ○ REDONDEZ (CIRCULARIDAD) ∅ CILINDRICIDAD ∩ PERFIL DE CUALQUIER SUPERFICIE ∪ PERFIL DE CUALQUIER LINEA ↑ VARIACION ⊕ POSICION REAL ⊙ CONCENTRICIDAD = SIMETRIA

A MENOS QUE SE ESPECIFIQUE DE OTRA MANERA, LAS TOLERANCIAS DE LAS DIMS; SON LAS SIGUIENTES: X XX XXX XXXX PULG ±.1 ±.02 ±.005 ±.0005 mm ±0.5 ±0.13 ±0.013 ANG. ±.50 GRADOS ELIMINAR REBABAS Y ORILLAS FILOSAS DEL BORDE. PULG .003-.015 mm 0.1-0.4 FILETEAR ESQUINA: PULG .020 mm 0.5 MAQUINAR SUPERFICIES PULG 125 mm 3.2 DIMS METRICAS MOSTRADAS [PARENTESIS]

DIBUJADO POR:	jrupert	09-08-2011
APROBADO POR:	jrupert	09-08-2011
TERCER ANGULO DE PROYECCION		FECHA EDS: 02-22-2008 REV. FORMATO: F
CONFIDENCIAL: ESTE DIBUJO Y SU INFORMACION SON PROPIEDAD DE USO EXCLUSIVO Y CONFIDENCIAL DE A.O.SMITH CORP. Y NO DEBERAN SER REVELADOS, DUPLICADOS, DISTRIBUIDOS O USARSE DE OTRA MANERA SIN EL CONSENTIMIENTO ESCRITO DE A.O. SMITH CORP. -TODOS LOS DERECHOS RESERVADOS.ASME Y14.5M 1994		

ELECTRICAL PRODUCTS COMPANY A DIVISION OF A. O. SMITH CORPORATION	
DESCRIPCION:	
CONN DIAGRAM-NAMEPLATE	
TAMAÑO: A	NUMERO DE DIBUJO: 614131-205
ESCALA:NONE	HOJA: 1

版本	ECO	编制	日期	批准	日期
B	ECO-0021846	jrupert	09-08-2011	jrupert	09-08-2011

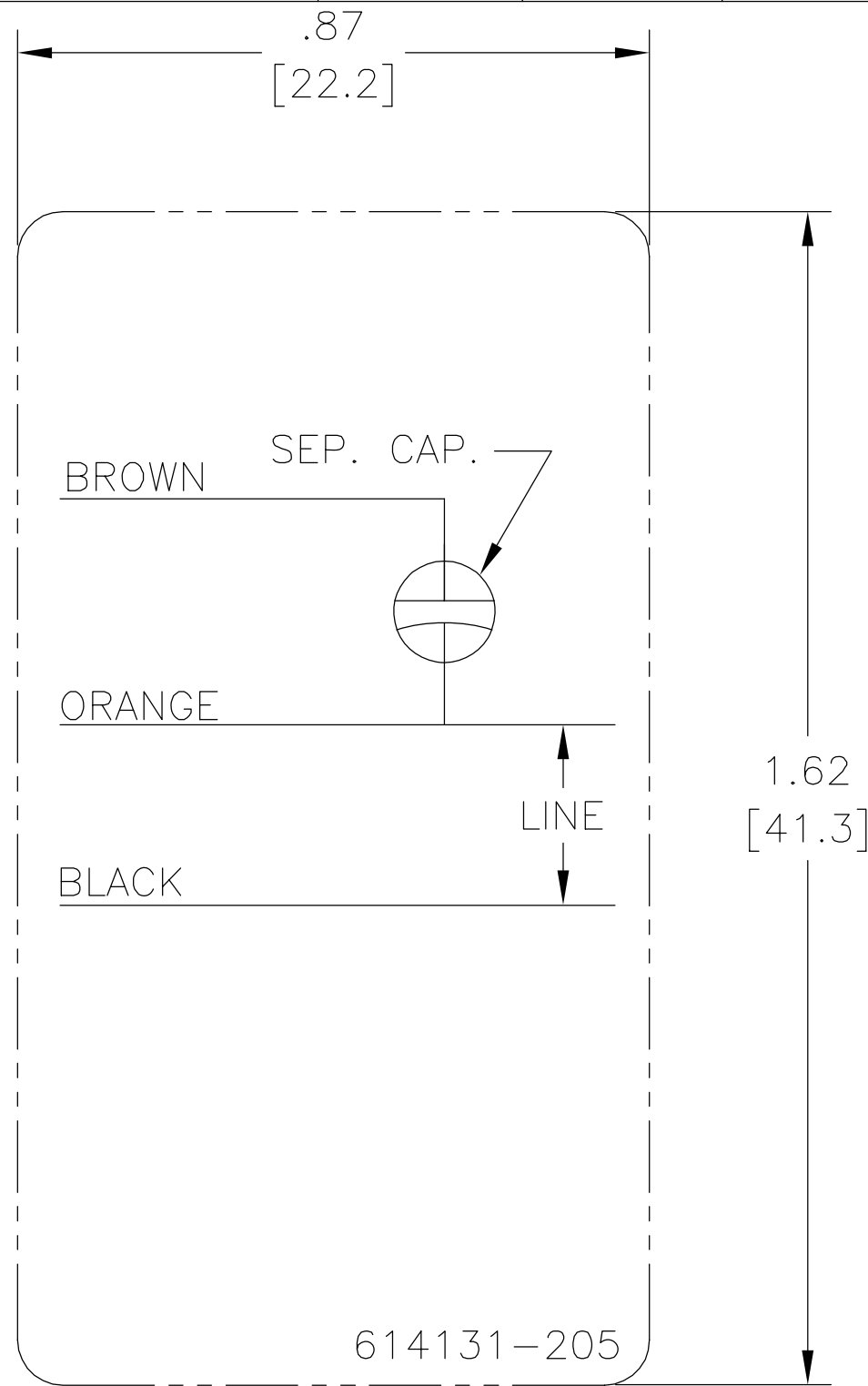

NOTES:

1. FOR USE WITH 614129 NAMEPLATE BLANK
2. — — — — — INDICATES DIMENSION LIMITS
3. DIE TO BE MADE FROM MASTER SUPPLIED BY A. O. SMITH CORPORATION
4. DIE MUST PRODUCE A LEGIBLE IMPRESSION.

形位公差	除另有注明
□ 平面度	尺寸公差如下:
— 直线度	英寸 X XX XXX XXXX
∠ 倾斜度	英寸 ±.1 ±.02 ±.005 ±.0005
⊥ 垂直度	毫米 ±0.5 ±0.13 ±0.013
// 平行度	角度 ±.50 度
○ 圆度	清理毛刺和尖棱
⊘ 圆柱度	英寸 .003-.015 毫米 0.1-0.4
△ 面轮廓度	内圆角
∩ 线轮廓度	英寸 .020 毫米 0.5
↑ 圆跳动	表面粗糙度
⊕ 位置度	英制 125 米制 3.2
◎ 同轴度	米制尺寸显示在 []
≡ 对称度	

绘图:	jrupert	09-08-2011
批准:	jrupert	09-08-2011
第三角投影		图纸格式发布日期 02-22-2008 图纸格式版本 F
机密: 本图纸及相关信息所有权归A. O. SMITH公司所有。未经A. O. SMITH公司书面授权, 不得泄露、复制、传播或作其他用途。— 版权所有		
ASME Y14.5M 1994		

		ELECTRICAL PRODUCTS COMPANY <small>A DIVISION OF A. O. SMITH CORPORATION</small>	
名称 CONN DIAGRAM-NAMEPLATE			
图幅	A	图号	614131-205
比例	NONE	页号	1

名称 CONN DIAGRAM-NAMEPLATE	
图幅	A
图号	614131-205
比例	NONE
页号	1