

# PRODUCT INFORMATION PACKET



Model No: GF2031L

Catalog No: GF2031L

Fan and Blower Motor, 1/3 HP, 1 Ph, 60 Hz, 115 V, 1800 RPM, 56Z Frame, OPEN



Regal and Century are trademarks of Regal Rexnord Corporation or one of its affiliated companies.

©2022 Regal Rexnord Corporation, All Rights Reserved. MC017097E





**Nameplate Specifications**

Output HP	1/3 Hp	Output KW	0.25 kW
Frequency	60 Hz	Voltage	115 V
Current	6.2 A	Speed	1725 rpm
Service Factor	1	Phase	1
Duty	Continuous	Insulation Class	B
Frame	56Z	Enclosure	Open Enclosed
Thermal Protection	No Protection	Ambient Temperature	40 °C
UL	No	CSA	Y
CE	N	Number of Speeds	1

**Technical Specifications**

Electrical Type	Split Phase	Starting Method	Across The Line
Poles	4	Rotation	Reversible
Mounting	Resilient Base	Drive End Bearing	Sleeve
Opp Drive End Bearing	Sleeve	Frame Material	Rolled Steel
Shaft Type	Flat	Overall Length	9.40 in
Frame Length	4.94 in	Shaft Diameter	0.500 in
Shaft Extension	1.62 in		
Connection Drawing	626987-001A	Outline Drawing	GF2031L-S01

This is an uncontrolled document once printed or downloaded and is subject to change without notice. Date Created:11/28/2022

CATALOG NUMBER	UL NUMBER	FRAME
GF2031L	E46412	56Z

REV	ECO	REV BY	DATE	APPD	DATE
A	ECO-0031789	J. COX	04-03-2013	C. McREYNOLDS	04-03-2013

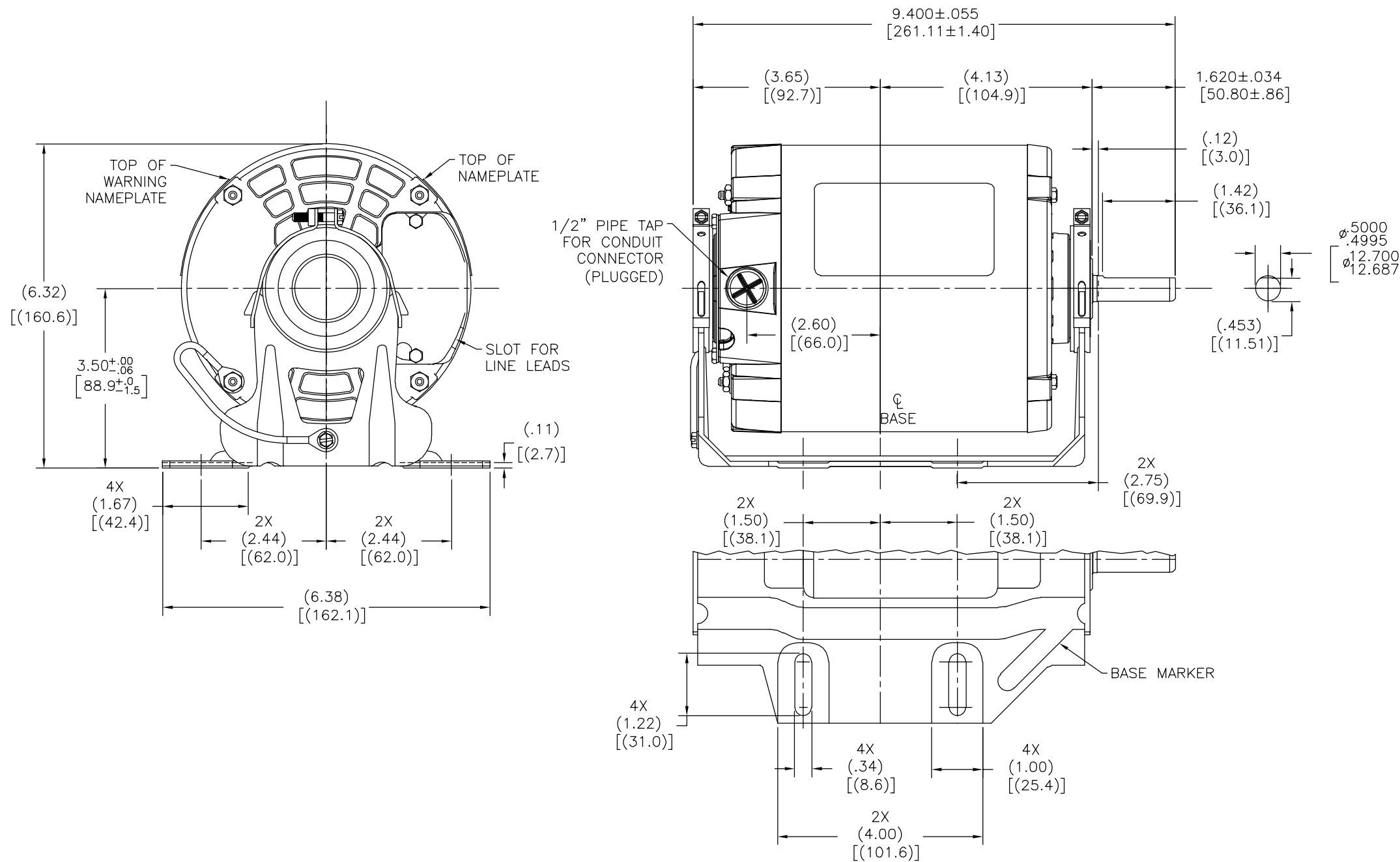

GEOMETRIC CHARACTERISTICS & SYMBOLS

- ▭ FLATNESS
- STRAIGHTNESS
- ∠ ANGULARITY
- ⊥ PERPENDICULARITY (SQUARENESS)
- // PARALLELISM
- ROUNDNESS (CIRCULARITY)
- ⊘ CYLINDRICITY
- △ PROFILE OF ANY SURFACE
- ⌒ PROFILE OF ANY LINE
- ↯ RUNOUT
- ⊕ TRUE POSITION
- ◎ CONCENTRICITY
- ≡ SYMMETRY

ASME Y14.5M 1994

UNLESS OTHERWISE SPECIFIED  
DIM. TOLERANCES ARE AS FOLLOWS:

INCH	±.1	±.02	±.005	±.0005
mm	±0.5	±0.13	±0.013	

ANG. ±.50 DEG  
REMOVE BURRS & BREAK SHARP EDGES:  
INCH .003-.015 mm 0.1-0.4  
CORNER FILLETS TO:  
INCH .020 mm 0.5  
MACHINE SURFACES:  
INCH 125 mm 3.2

METRIC DIMS. SHOWN IN [BRACKETS]

DR BY:	J. COX	04-03-2013
APPD:	C. McREYNOLDS	04-03-2013
THIRD ANGLE PROJECTION		EDS DATE 11-11-2011 FORMAT REV H
CONFIDENTIAL: THIS DRAWING AND ITS INFORMATION ARE THE EXCLUSIVE AND CONFIDENTIAL PROPERTY OF REGAL-BELOIT CORPORATION AND ARE NOT TO BE DISCLOSED, DUPLICATED, DISTRIBUTED OR OTHERWISE USED WITHOUT THE WRITTEN CONSENT OF REGAL-BELOIT CORPORATION. -ALL RIGHTS RESERVED.		

<b>REGAL-BELOIT CORPORATION</b>	
DESCRIPTION <b>MODEL-RFHP-56FR OUTLINE</b>	
SIZE <b>C</b>	DWG NO <b>GF2031L</b>
SCALE NONE	SHEET 1