

MCGILL® TRAKROL Cam Follower Bearings

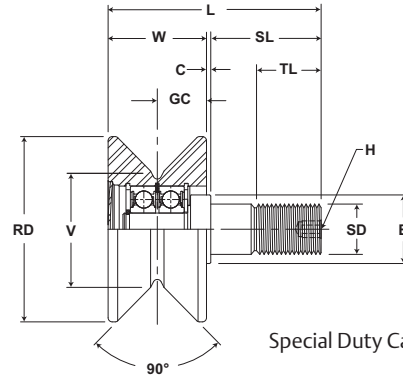

- Basic Construction Type:** Stud Type V-Grooved Outside Diameter
- Rolling Elements:** Ball or Tapered Roller Bearing Insert
- Bearing Material:** Bearing Quality Steel
- Seal Type:** Metal Extension Plug and Rubber Lip Seal Ball
- Lubrication:** Polyurea Thickened Grease NLGI #2
- Stem Configuration:** Concentric / Eccentric
- Mounting Feature:** Hex Hole on Thread Face



Special Duty Cam Follower

VCF

Part No.	Insert Type	RD	W	V	GC	SD		SL	C	L		ECC	G	BD
With LUBRI-DISC Seals	Ball or Tapered Roller Bearing	Roller Diameter	Roller Width	Point Diameter	Groove Center	Stud Diameter		Stud Length	Endplate Extension	Length Overall	Thread Length	Eccentric Base Modifier VCFE-XX		
		inch mm	inch mm	inch mm	inch mm	inch mm		inch mm	inch mm	inch mm	inch mm	inch mm		
		(Ref)	(Ref)	(Ref)	(Ref)	Nom.	Tol.	(Ref)	(Ref)	(Ref)	(Ref)	(Ref)	+0/- .010	±.001
VCF 2 1/2	BB	2.50 63.5	1.31 33.3	1.50 38.1	.69 17.5	1.00 25.4	+0/-0.001 +0/- 0.03	1.75 44	0.06 2	2.94 75	0.88 22	-	-	-
VCFE 2 1/2		.03 1	.86 22	1.00 25										
VCF 3 1/2	BB	3.50 88.9	1.69 42.9	2.25 57.2	.88 22.2	1.25 31.8	+0/-0.001 +0/- 0.03	2.00 51	0.06 2	3.69 94	1.13 29	-	-	-
VCFE 3 1/2		.03 1	.98 25	1.19 30										
VCF 4 1/2	TRB	4.50 114.3	2.00 50.8	3.00 76.2	1.00 25.4	1.25 31.8	+0/-0.001 +0/- 0.03	2.50 64	0.06 2	4.50 114	1.75 44	-	-	-
VCFE 4 1/2		.06 2	1.23 31	1.75 44										
VCF 5 1/2	TRB	5.50 139.7	2.00 50.8	4.00 101.6	1.00 25.4	1.25 31.8	+0/-0.001 +0/- 0.03	2.75 70	0.06 2	4.75 121	1.75 44	-	-	-
VCFE 5 1/2		.06 2	1.36 34	1.81 46										
VCF 6 1/2	TRB	6.50 165.1	3.00 76.2	5.00 127.0	1.50 38.1	2.00 50.8	+0/-0.001 +0/- 0.03	4.50 114	0.06 2	7.50 191	2.50 64	-	-	-
VCF 7 1/2	TRB	7.50 190.5	3.00 76.2	6.00 152.4	1.50 38.1	2.50 63.5	+0/-0.001 +0/- 0.03	5.50 140	0.06 2	8.50 216	3.25 83	-	-	-
VCF 8 1/2	TRB	8.50 215.9	3.00 76.2	7.00 177.8	1.50 38.1	2.50 63.5	+0/-0.001 +0/- 0.03	5.50 140	0.06 2	8.50 216	3.25 83	-	-	-

*Dynamic thrust load rating based on application of a centric, axial load. Fatigue life calculations for combined radial and thrust loading require special considerations and Application Engineering should be contacted.

Metric dimensions for reference only.

Not all parts are available from stock. Please contact customer service for availability (800) 626-2120.

For more information on bearing capabilities outside of our standard offering, please contact Application Engineering (800) 626-2093.

TRAKROL Cam Follower Bearings **McGILL**

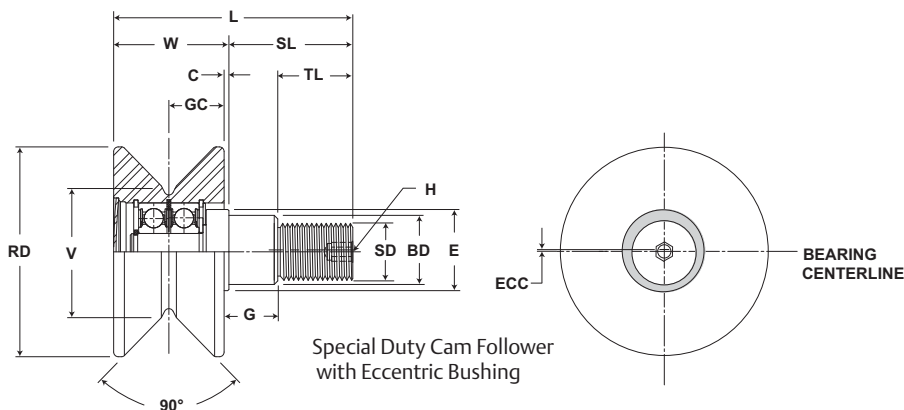

VCF

Track Roller Dynamic Rating	Thrust Capacity	Track Roller Static Rating	H	E	Housing Bore Diameter		Thread Type	Clamping Torque	WT
			Hex Hole	Min. Clamping Diameter					Bearing Weight
			inch mm	inch mm	Nom.	Tol.		in-lb Nm	lb kg
2,520 11,209	1,320 5,871	1,370 6,094	.25 6	1.0 25	.7510 19	+ .0002/- .0003 + .0005/- .0008	3/4-16	1,250 142	1.3 .59
					1.003 25.47	±.001 ±.025			
3,490 15,524	1,830 8,140	2,000 8,896	.38 10	1.0 25	.8760 22	+ .0002/- .0003 + .0005/- .0010	7/8-14	1,500 170	3.2 1.45
					1.190 30.23	±.001 ±.025			
14,300 63,606	5,790 25,754	16,000 71,168	.44 11	1.75 44	1.2510 32	+ .0002/- .0003 + .0005/- .0013	1 1/4-12	3,440 388	6.8 3.08
					1.753 44.52	±.001 ±.025			
14,300 63,606	5,790 25,754	16,000 71,168	.44 11	1.75 44	1.2510 32	+ .0002/- .0003 + .0005/- .0015	1 1/4-12	3,440 388	10.7 4.85
					1.815 46.10	±.001 ±.025			
35,800 159,238	13,300 59,158	40,000 177,920	.88 22	3.25 83	2.0010 51	+ .0002/- .0003 + .0005/- .0017	2-12	5,000 566	26.1 11.84
35,800 159,238	14,200 63,162	62,000 275,776	.88 22	3.25 83	2.5010 64	+ .0002/- .0003 + .0005/- .0018	2 1/2-12	5,000 566	34.0 15.42
35,800 159,238	14,200 63,162	62,000 275,776	.88 22	3.25 83	2.5010 64	+ .0002/- .0003 + .0005/- .0019	2 1/2-12	5,000 566	45.0 20.41

Clamping torque is based on dry threads. If threads are lubricated, use half of value shown.