

# PRODUCT INFORMATION PACKET

Model No: 098069.00

Catalog No: 098069.00

SCR Motor, 0.75 HP, 180 V, 1750 RPM, SS56C Frame, TEFC



Regal and are trademarks of Regal Rexnord Corporation or one of its affiliated companies.  
©2022 Regal Rexnord Corporation, All Rights Reserved. MC017097E

**Nameplate Specifications**

Output HP	0.75 Hp	Output KW	0.56 kW
Voltage	180 V	Current	3.8 A
Speed	1750 rpm	Service Factor	1
Efficiency	82.1 %	Duty	Continuous
Insulation Class	F	Frame	SS56C
Enclosure	Totally Enclosed Fan Cooled	Thermal Protection	No Protection
Ambient Temperature	40 °C	Drive End Bearing Size	6203
Opp Drive End Bearing Size	6203	UL	Recognized
CSA	Y	CE	N

**Technical Specifications**

Rotation	Reversible	Mounting	Rigid C base
Overall Length	13.81 in	Frame Length	9.50 in
Shaft Diameter	0.625 in	Shaft Extension	2.06 in
Torque	27 LB-IN		
Outline Drawing	027620-098069	Connection Drawing	00531901

This is an uncontrolled document once printed or downloaded and is subject to change without notice. Date Created:09/19/2022

RBC PROPRIETARY AND CONFIDENTIAL INFORMATION  
 This document is the property of REGAL BELOIT CORPORATION ("RBC") including its subsidiaries and divisions and contains proprietary information of RBC. This document is loaned on the express condition that neither it nor the information contained therein shall be disclosed to others without the express written consent of RBC, and that the information shall be used by the recipient only as approved expressly by RBC. This document shall be returned to RBC upon its request. This document may be subject to certain restrictions under U.S. export control laws and regulations.

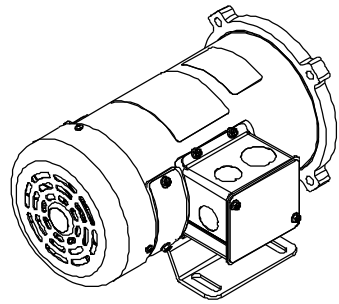
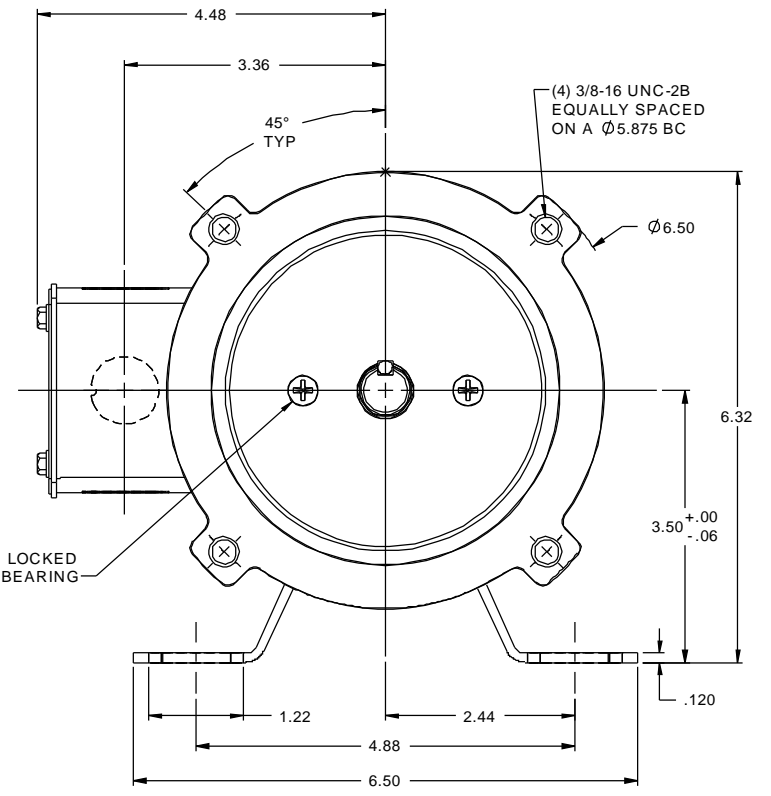
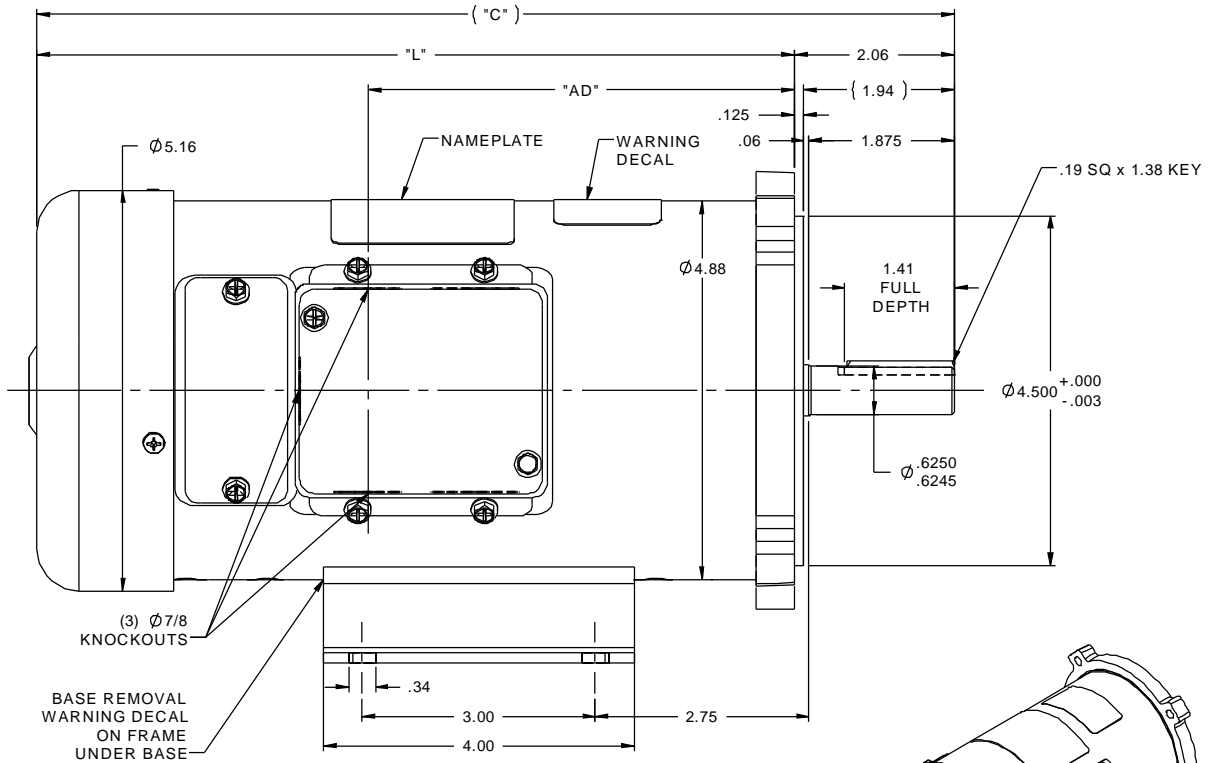

- NOTES:  
 1) MAXIMUM FACE RUNOUT .004 T.I.R.  
 2) MAXIMUM PILOT ECCENTRICITY .004 T.I.R.  
 3) PERMISSIBLE SHAFT RUNOUT .002 T.I.R.  
 4) GASKETS THROUGHOUT.

098382.00	10.81	8.75	4.49	48	1/2	1800
098381.00	10.81	8.75	4.49	36	1/2	1800
098069.00	13.81	11.75	7.49	180	3/4	1750
098032.00	13.81	11.75	7.49	90	3/4	1750
098010.00	11.81	9.75	5.49	180	3/4	2500
098009.00	11.81	9.75	5.49	90	3/4	2500
098008.00	11.81	9.75	5.49	180	1/2	1750
098007.00	10.81	8.75	4.49	180	1/2	2500
098006.00	10.81	8.75	4.49	90	1/2	2500
098005.00	11.31	9.25	4.99	180	1/3	1750
098004.00	11.31	9.25	4.99	90	1/3	1750
098003.00	11.31	9.25	4.99	180	1/4	1750
098002.00	10.81	8.75	4.49	90	1/4	1750
098000.00	11.81	9.75	5.49	90	1/2	1750
CATALOG No.	"C"	"L"	"AD"	VOLTS	H.P.	RPM

		TOLERANCES UNLESS SPECIFIED		DRAWN JRA 5/11/95	
		DEC INCHES		CHK	
		X ±.1		APPR	
08	REDRAWN IN SOLIDWORKS, MODIFIED TABLE PER NEW STANDARD	IPG 9/8/2011	XX ±.03	TITLE OUTLINE	
			XXX ±.005	42 FRAME DC - SS56C MOUNT	
07	ADDED FAN GUARD HOLE PLUG, ISAAC 10-4174	IPG 10/11/10	XXXX ±.0005	MATL	
			ANG ±1/2°	FINISH	
NO	REVISION	BY & DATE	CHK	PREV	
			RFP	PAGE OF	
			ANG	DRAWING NO	
			PREV	REV	
			NETWORK FILE NAME 027620	SIZE B	
				DRAWING NO 027620	
				REV 08	



ELECTRIC MOTORS  
 GEARMOTORS  
 AND DRIVES



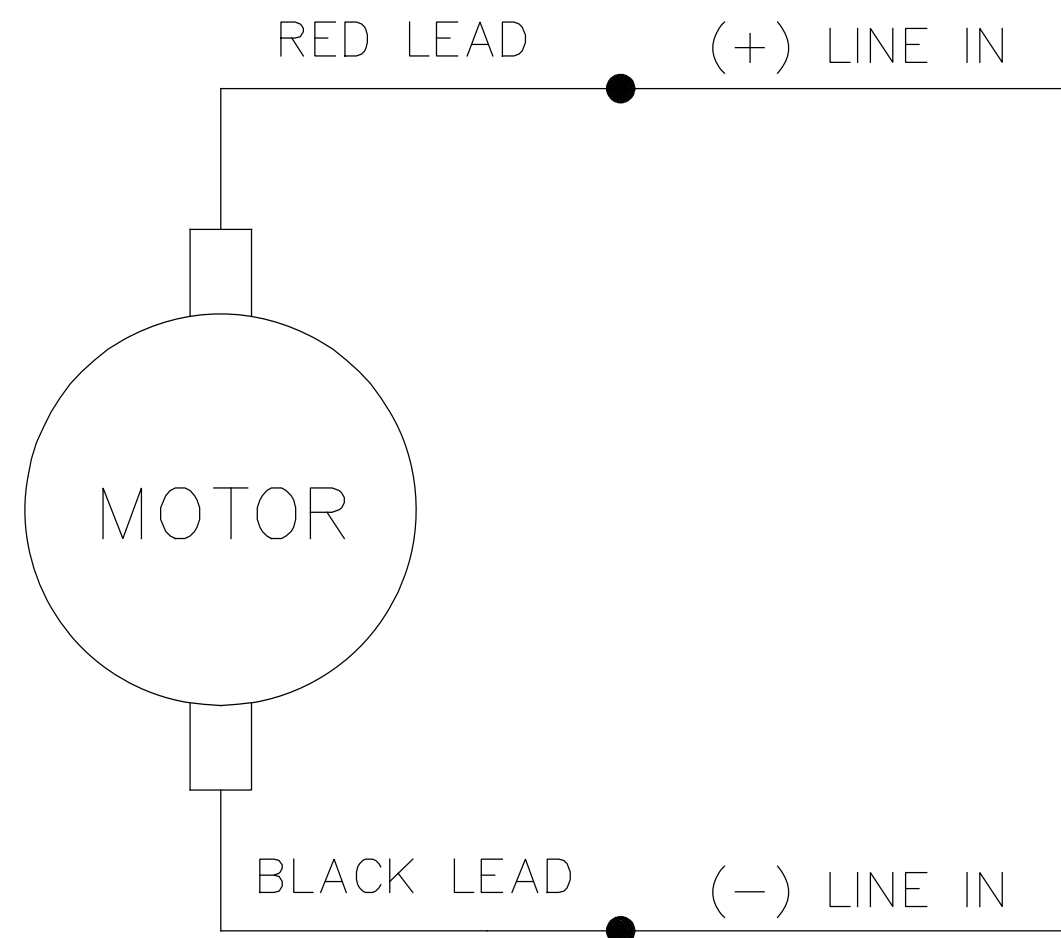

CONNECTIONS SHOWN FOR CCW ROTATION FACING LEAD END OF THE MOTOR  
TO REVERSE ROTATION INTERCHANGE LINE LEADS

NO.	REVISION	BY & DATE	CHK	TOLERANCES UNLESS SPECIFIED		LEESON	ELECTRIC MOTORS GEARMOTORS AND DRIVES	DRAWN TJF 11/15/97	
				DEC.	INCHES				CHK
				.X	±.1			APPD POW 11/15/97	
E	"MOTOR" WAS "ARMATURE", ECO-0163602	IPG 3/14/19		.XX	±.01	TITLE	EXTERNAL WIRING DIAGRAM PMDC MOTOR	SCALE 1=2	
D	UPDATED TO MAKE IT GENERIC, ECO-0163547	IPG 3/13/19		.XXX	±.005			REF	
01	REDRAWN ON CAD. REVISED NOTES.	SJB 9/20/2005		.XXXX	±.0005	MAT'L.		FMF	
				ANG	±1/2°	FINISH		PREV	
THIS DRAWING IN DESIGN AND DETAIL IS OUR PROPERTY AND MUST NOT BE USED EXCEPT IN CONNECTION WITH OUR WORK ALL RIGHTS OF DESIGN AND INVENTION ARE RESERVED THIS IS AN ELECTRONICALLY GENERATED DOCUMENT - DO NOT SCALE THIS PRINT				RFP	CAD FILE 00531901		SIZE A	DRAWING NO. 005319.01	REV. E
				DIST					

# LEESON ELECTRIC CORPORATION

## TYPICAL PERFORMANCE CURVE FOR DIRECT CURRENT PERMANENT MAGNET MOTOR

Model No. <u>C42D17FK11</u>	Catalog No. <u>098069.00</u>	
HP <u>0.750</u>	RPM <u>1750</u>	DC Volts <u>180.0</u>
F.F. <u>1.38</u>	Encl <u>TEFC</u>	N.P. FLA <u>3.80</u>
Max. Amb. <u>40.0 Deg C</u>	Insul. <u>F</u>	Type <u>DF</u>
		Frame <u>USS56C</u>
		S.F. <u>1.00</u>
		Duty <u>Cont</u>

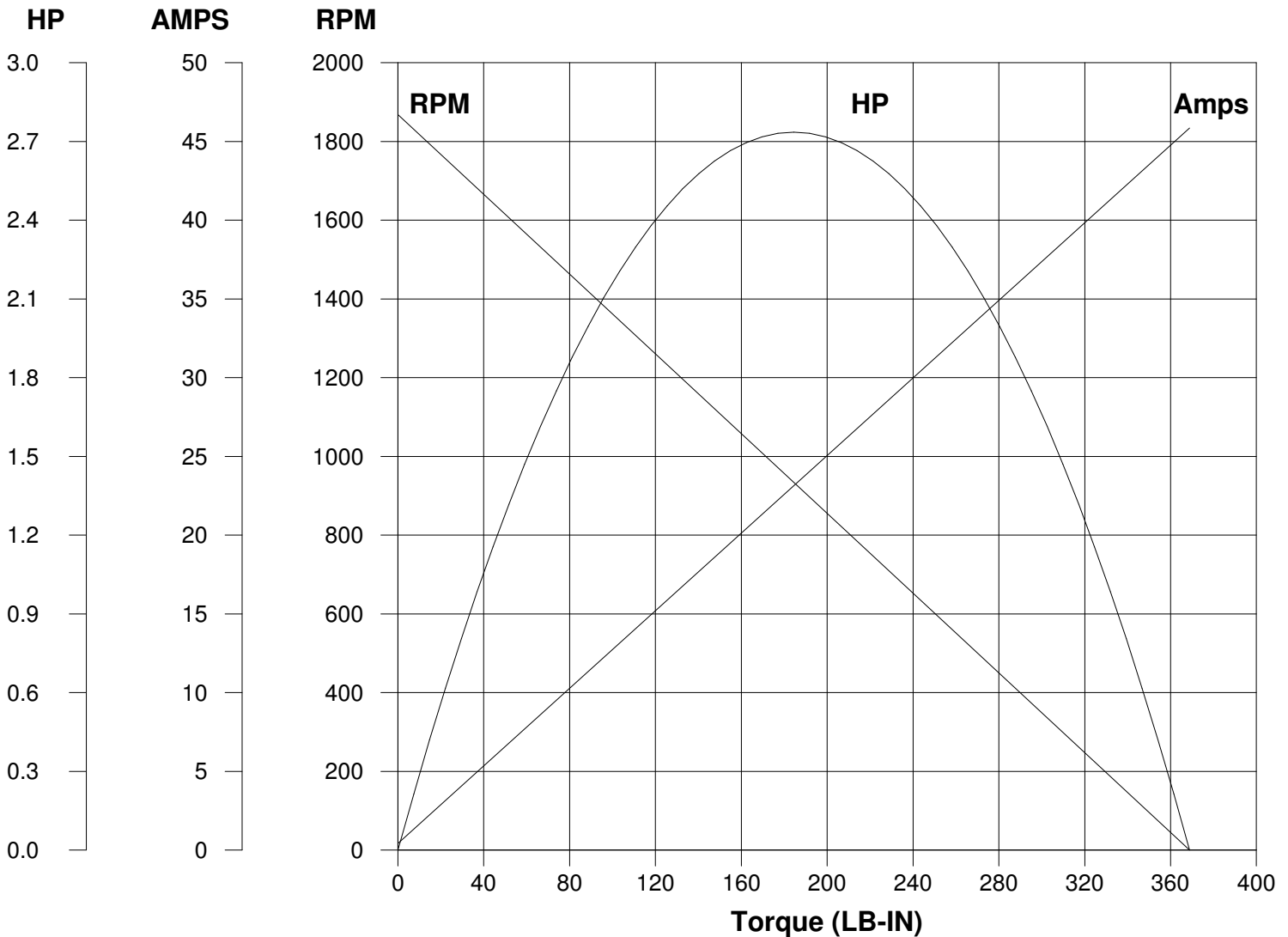

**Ra** 2.5500 Ohms  
**La** 39.00 mHenrys  
**Ja** 12.50 LB-IN<sup>2</sup>  
**Ke** 95.69 V/KRPM

**Kt** 8.089 LB-IN/AMP  
**Imax** 42.2 AMPS Allowed  
**FL Torque** 27.00 LB-IN  
**FL EFF** 82.20 %

**Winding W-** D472294-1      **Prepared by** V. Boehlen      **Date** 04-29-2005