

PRODUCT INFORMATION PACKET

Model No: 5KH42JN0328S

Catalog No: H247

General Purpose Farm Duty Motor, 0.50 HP, 1 Ph, 60 Hz, 115/208-230 V, 1800 RPM, 56 Frame, TEAO



Regal and Marathon are trademarks of Regal Rexnord Corporation or one of its affiliated companies.

©2022 Regal Rexnord Corporation, All Rights Reserved. MC017097E



Nameplate Specifications

Output HP	0.50 Hp	Output KW	0.37 kW
Frequency	60 Hz	Voltage	115/208-230 V
Current	8.0,4.0-4.0 A	Speed	1725 rpm
Service Factor	1	Phase	1
Efficiency	61.7 %	Power Factor	0
Duty	Continuous Air Over	Insulation Class	B
KVA Code	R	Frame	56
Enclosure	Totally Enclosed Air Over	Thermal Protection	Automatic
Ambient Temperature	40 °C	Drive End Bearing Size	6203
Opp Drive End Bearing Size	6203	UL	Recognized
CSA	Yes	CE	N
Number of Speeds	1		

Technical Specifications

Electrical Type	Split Phase	Starting Method	SM
Poles	4	Rotation	Counterclockwise/Clockwise
Mounting	Resilient Base	Motor Orientation	ANY
Drive End Bearing	BALL	Opp Drive End Bearing	Ball
Frame Material	Rolled Steel	Overall Length	10.05 in
Frame Length	5.72 in	Shaft Diameter	0.630 in
Shaft Extension	1.88 in		
Outline Drawing	52A109678P1	Connection Drawing	52A105383AA

This is an uncontrolled document once printed or downloaded and is subject to change without notice. Date Created:11/28/2022

52A109678

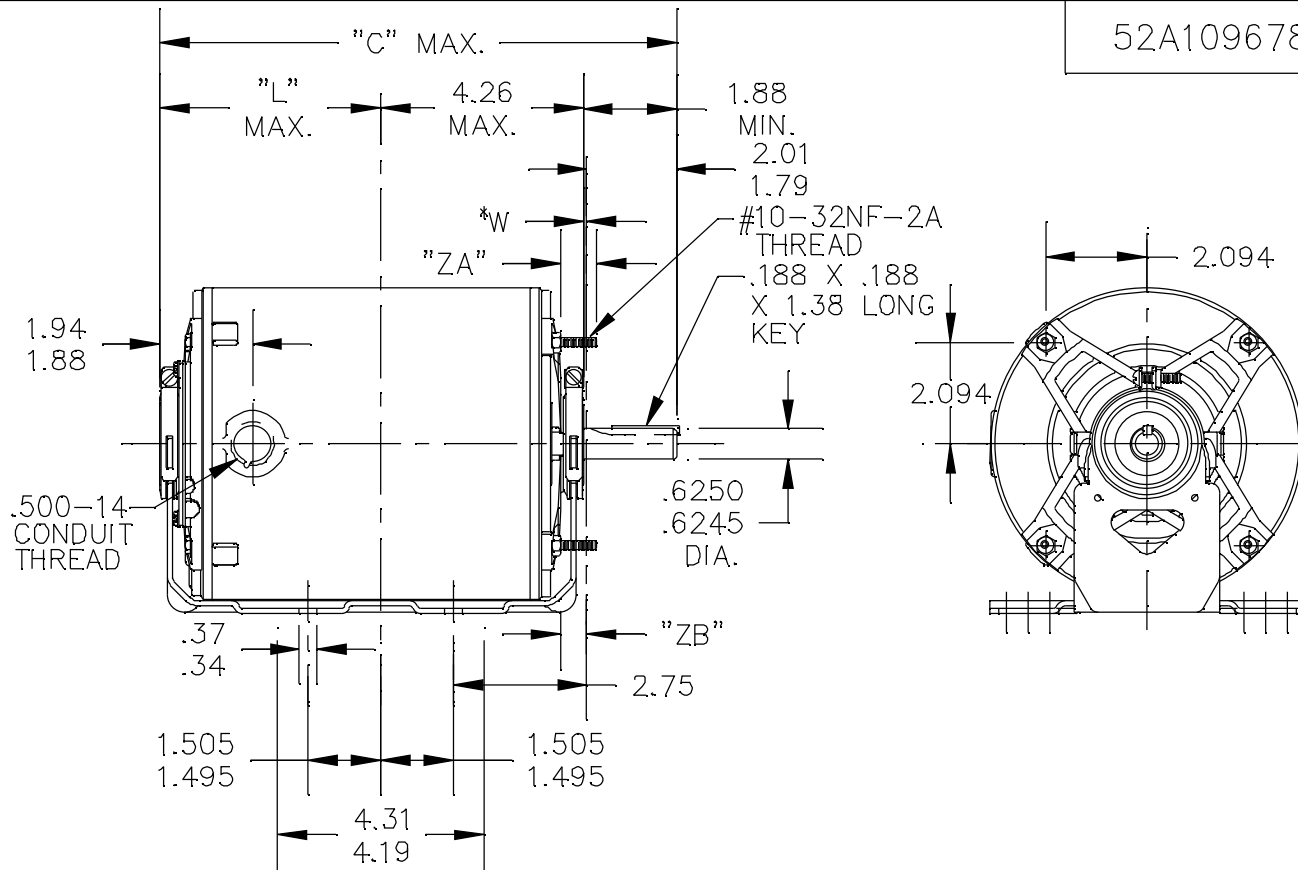
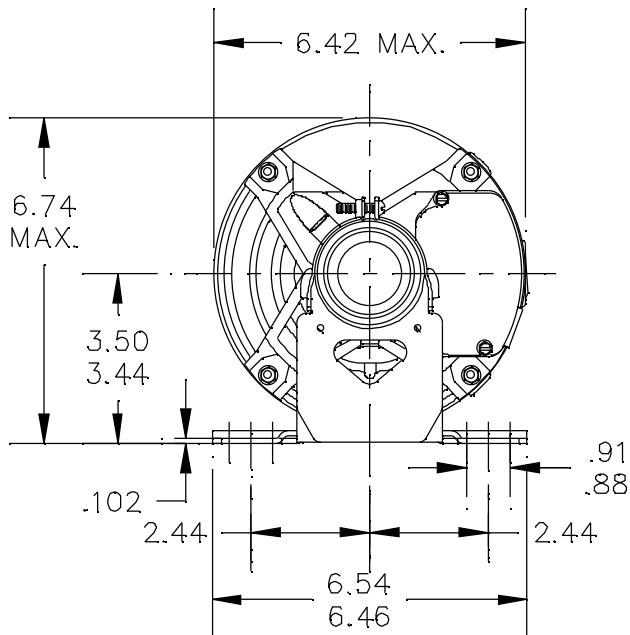

*W IS A VARIABLE CLEARANCE DUE TO VARIATIONS IN PARTS AND ASSEMBLY

ALL DIMENSIONS ARE IN INCHES

2	KH	46	56	10.88	4.62	.62	.51/.44			6.55
1	K	42	56	10.05	3.79	.62	.51/.44			5.72
P	TYPE	RBC SIZE	NEMA FR.	"C"	"L"	"ZA"	"ZB"			MIN. SHELL

				TOLERANCES UNLESS SPECIFIED		 REGAL-BELOIT CORPORATION		DRAWN M.D.P 09/08/94	
				DEC.	INCHES			CHK	
4	REDRAWN IN DRAFT SIGHT NO CHANGES	PVR	10/16/12	PKG	.X	±0.1	TITLE OUTLINE TENV - RESILIENT BASE EXTENDED CLAMP SCREWS		APPD M.D.P 09/08/94
3	ADDED PART #2 PER DS10-0176	AB	02/26/10		.XX	±0.02			SCALE 1=1
2	CHG TO RBC FORMAT PER IS05-1777	SUDHA	3/23/06		.XXX	±0.005			REF
1	ADDED DIM. "ZB"	M.A.M09	20/94		.XXXX	±0.0005			FMF
NO.	REVISION	BY & DATE	CHK	ANG	±1.0	FINISH	PREV		

THIS DRAWING IN DESIGN AND DETAIL IS OUR PROPERTY AND MUST NOT BE USED EXCEPT IN CONNECTION WITH OUR WORK ALL RIGHTS OF DESIGN AND INVENTION ARE RESERVED THIS IS AN ELECTRONICALLY GENERATED DOCUMENT - DO NOT SCALE THIS PRINT

RFP	CAD FILE	52A109678	SIZE	DRAWING NO.	REV.
DIST			A	52A109678	4

EITHER ROTATION, DUAL VOLTAGE, TYPE KC OR KH, WITH THERMAL PROTECTION

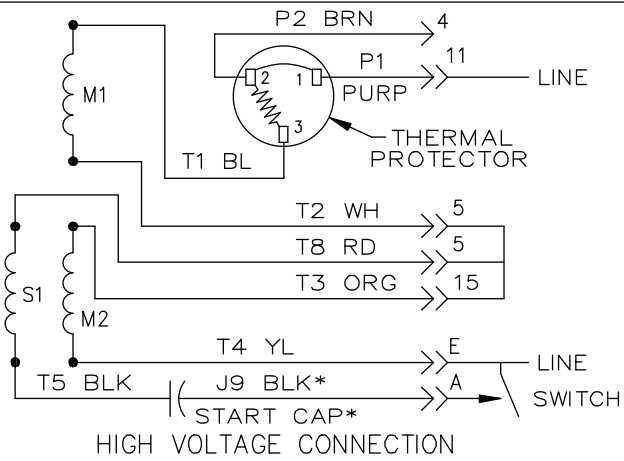
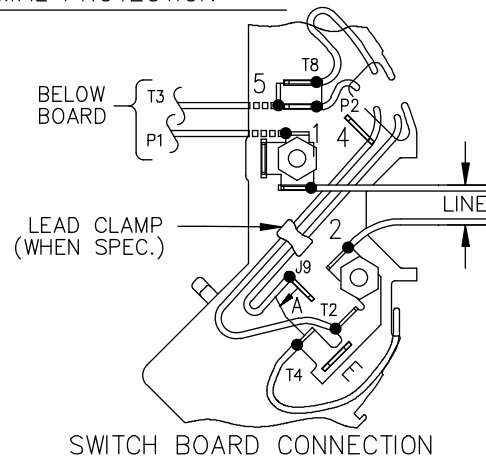
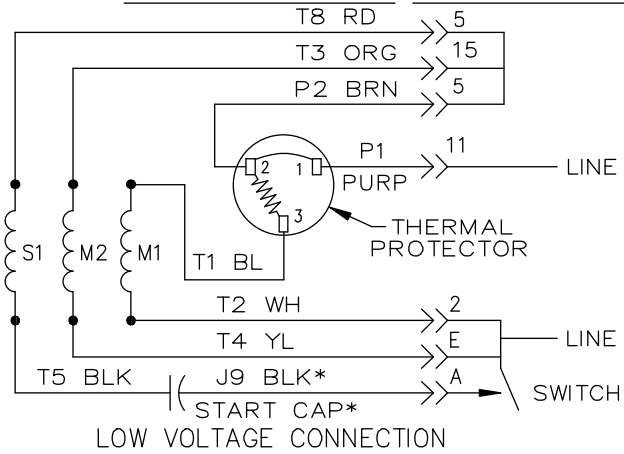

NOTE #1 - START CAP & J9 WHEN SPECIFIED (*). IF NO CAPACITOR (KH), CONNECT T5 DIRECTLY TO SWITCH (A). WHEN MORE THAN ONE CAPACITOR IS USED, CONNECT IN PARALLEL.

NOTE #2 - TO REVERSE ROTATION, INTER CHANGE RD(T8) AND BLK(J9-KC OR T5-KH) LEADS.

SWITCH REF. - 115D958AB	CONNECTION LABEL	CCW ROTATION: NP52X332051AA
		CW ROTATION: NP52X332051AC

NO.	REVISION	BY & DATE	CHK	TOLERANCES UNLESS SPECIFIED		FINISH	DRAWN		
				DEC.	INCHES				
				.X	±0.1		M.D.P 06/29/87		
				.XX	±0.02		CHK		
				.XXX	±0.005		APPD M.D.P 03/26/96		
				.XXXX	±0.0005		SCALE 1=1		
5	ADDED CONNECTION LABEL PER ECO-0030779	UD 02/06/13	PKG	ANG	±1.0		REF		
4	UPDATED PER ISO7-0150	MD 01/23/07					FMF		
							PREV		
THIS DRAWING IN DESIGN AND DETAIL IS OUR PROPERTY AND MUST NOT BE USED EXCEPT IN CONNECTION WITH OUR WORK. ALL RIGHTS OF DESIGN AND INVENTION ARE RESERVED. THIS IS AN ELECTRONICALLY GENERATED DOCUMENT - DO NOT SCALE THIS PRINT				RFP	CAD FILE	52A105383AA	SIZE	DRAWING NO.	REV.
				DIST			A	52A105383AA	5



TITLE CONNECTION DIAGRAM
30 FRAME SWITCH REDESIGN